

80MSPS 12-bit Analog Input Board  
for PCI Express  
**AI-80M1202-PE**



\* Specifications, color and design of the products are subject to change without notice.

**Features**

**Maximum conversion speed is 80MSPS (12.5nsec), with simultaneous sampling of 2channels at a time**

The maximum conversion speed is 80MSPS (12.5nsec) and 2channels can be sampled simultaneously. The range for each channel can be set independently by software to match the level of the input signal source. (Input range : ±10V, ±5V, ±1V)

Also features digital inputs and outputs (four LVTTTL level input and output ports respectively).

(requires the optional DT-E3 cable)

**Sampling can be controlled by software, conversion data comparison, external trigger, and similar start and stop conditions**

Sampling can be setup to be started and stopped by software, conversion data comparison, or external trigger.

Control of sampling start and stop is completely independent and a separate setting is provided for each. It is also possible to specify that sampling stop after a specified number of samples.

The conversion data comparison function can perform level, in-range, and out-of-range comparisons on the conversion data.

**Bus master transfer function allows continuous data acquisition at high speed**

The bus master transfer function makes it possible to transfer data at high speed between a PC and its cards. This function allows for the acquisition of a large amount of sampling data at high speed.

**BNC connector used for analog input pin**

The BNC connector used for the analog input has a characteristic impedance of 50Ω and is of a type commonly used for high speed analog signals. This makes it easy to connect to other devices with a BNC connector.

**Termination resistor selection function**

A 50Ω termination resistor can be set to minimize the distortion caused by the reflection of high-speed input signals. When the termination resistor is enabled, you cannot apply voltage that meets or exceeds +5V or meets or is less than -5V.

**Filter available for analog input signals**

By enabling the filter (low-pass filter: 20MHz) function on analog input signals, you can reduce the effect of high-frequency noise that mixes in from the signal source or the ambient environment.

This product is a PCI Express bus-compliant interface board used to provide an analog signal input function on a PC.

Maximum conversion speed is 80MSPS (12.5nsec), with simultaneous sampling of two channels at a same time.

Maximum conversion speed is 80MSPS (12.5nsec), with simultaneous sampling of two channels at a same time. The bus master transfer function allows for the acquisition of a large amount of sampling data at high speed. Sampling can be started and stopped by software, conversion data comparison (level comparison, in-range comparison, out-of-range comparison), or external trigger.

By using an external reference clock, you can improve the accuracy of the frequency and synchronize the product with the hardware clocks of other devices.

Uses a BNC connector that can connect directly to the signal source.

Also features four digital input and output ports respectively (requires the optional DT-E3 cable).

Windows device driver is supported with this product.

- \* The contents in this document are subject to change without notice.
- \* Visit the CONTEC website to check the latest details in the document.
- \* The information in the data sheets is as of March, 2026.

**Digital filter function included to prevent misdetection due to chattering on external input signals**

A digital filter is included to prevent misdetection due to chattering on the digital input signals.

**Software-based adjustment function**

Use software to adjust the offset of the analog input. Apart from the adjustment information prepared before shipment, additional adjustment information can be stored according to the use environment.

**Windows support device driver**

Using the device driver API-TOOL makes it possible to create applications of Windows. In addition, a diagnostic program by which the operations of hardware can be checked is provided.

**Product Lineup**

- Product ... 1
- Please read the following ... 1
- 6-pin connector ... 1

**Supported OS**

You can use CONTEC support software according to your purpose and development environment.

For more details on the supported OS, applicable languages, or to download the latest version of software, visit the CONTEC Web site.

Name	Contents	How to get
Windows Version Analog I/O Driver software API-AIO(WDM)	The Windows device driver is provided as a form of Windows API functions. Various sample programs such as C# and Visual Basic .NET, Visual C++, Python etc. and diagnostic program useful for checking operation is provided.	Download from the CONTEC website *1
Software Development Tool Kits (SDK) and Support Software	In addition to the device drivers, we offer many software programs for using CONTEC devices in an easier manner.	Download from the CONTEC website *2

\*1 Download the files from the following URL.  
<https://www.contec.com/download/>

\*2 For supported software, search the CONTEC website for the product and view the product page.  
<https://www.contec.com/>

## Specifications

Item	Specifications	
Analog input	Isolated specification	Unisolated
	Input type	Single-Ended Input
	Input channel	2ch
	Input range	(when 50Ω termination setting disabled) ±10V, ±5V, ±1V (when 50Ω termination setting enabled) ±5V, ±1V
	Maximum input voltage *1	(when 50Ω termination setting disabled) ±13V (Max) (when 50Ω termination setting enabled) ±5.5V (Max)
	Input impedance	1MΩ±1% // 15pF typ. 50Ω±1%(when 50Ω termination setting enabled)
	Resolution	12bit
	Conversion accuracy *2*4	Within ±8LSB (input range : ±10V) Within ±12LSB (input range : ±5V) Within ±12LSB (input range : ±1V)
	Non-linear error *2*3*4	±1%
	Conversion speed	12.5nsec (Max)
	Passband (-3dB)	40MHz *5
	Filter band (-3dB)	20MHz, Low-pass filter (FIR, 31st order, Hanning window)
	Buffer memory	512M data (Max)
	Conversion start trigger	Software, conversion data compare and external trigger
	Conversion stop trigger	Settings include data save complete, conversion data compare, external trigger, and software.
	External start signal	Input Level: LVTTTL level (Rising or falling edge can be selected by software) *6*7
	External stop signal	Input Level: LVTTTL level (Rising or falling edge can be selected by software) *6*7
	External status output signal	High: Sampling is in operation Low: Sampling is stopped Output level: LVTTTL
Internal reference clock	Frequency	10MHz
	Frequency Accuracy	±5ppm (Temperature drift : ±2.5ppm/°C (0 - 50°C), Aging : ±1ppm/year)
Reference clock input	Input frequency	10MHz (Duty cycle must be within 50% ± 5%)
	Input impedance	600Ω typ.
	Input coupling	AC
	Input voltage	0.2Vpk - 3.3Vpk
	Maximum input voltage	±5V
Digital input	Number of input channels	4ch
	Input type	Non-isolated input (LVTTTL level *6*7, positive logic)
Digital output	Number of output channels	4ch
	Output format	Non-isolated output (LVTTTL level *6*7, positive logic)
Bus master section	DMA channels	1ch
	Transfer bus width	64bit
	Transfer rate	360MByte/s
	FIFO	8k Word/ch
Common section	Memory addresses	Occupies 2 locations 256MByte
	Connector used	For analog (CN2,3), reference clock input (CN4) : BNC connector B-901W1AAN03 equivalent [mfd. By INSERT ENTERPRISE]. For trigger input, status output (CN1): 6 pin terminal block connector MC 0, 5/6-G-2, 5 THT [mfd. By Phoenix Contact]. For digital input/output (CN5) : 16pin pin header connector
	Current consumption	3.3VDC 1500mA, 12V 350mA (Max)
	Bus specification	PCI Express Base Specification Rev.2.0 x1
	Physical dimensions (mm)	169.55(L) x 110.18(H)
	Weight	200g

- \*1 Do not input voltages in excess of the maximum input voltage. Similarly, do not input voltage exceeding 1.5 times the range being used, even if less than the maximum input voltage. Inputting too high a voltage may cause a fault.
- \*2 The rated precision may not be achieved depending on the cable used.
- \*3 The non-linearity error means an error of approximately 0.1% occurs over the maximum range at 0°C and 50°C ambient temperature.
- \*4 A 6166[ADC] voltage generator was used for measurements.
- \*5 When set to the ±10V range.
- \*6 Inputting a 5V TTL signal is possible.
- \*7 Allowable distance of signal extension : Approx. 1.5m (depending on wiring environment)

## Installation Environment Requirements

Item	Specifications	
Operating ambient temperature	0 - +50°C	
Operating ambient humidity	10 - 90%RH (No condensation)	
Floating dust particles	Not to be excessive	
Corrosive gases	None	
Line-noise resistance	Line noise	AC Line/±2kV Signal Line /±1kV(IEC61000-4-4 Level 3, EN61000-4-4 Level 3)
	Static electricity resistance	Touch /±4kV(IEC61000-4-2 Level 2, EN61000-4-2 Level 2) Air /±8kV(IEC61000-4-2 Level 3, EN61000-4-2 Level 3)
	Sweep resistance	10 - 57Hz /semi-amplitude vibration 0.15mm, 57 - 150Hz/2.0G 40minutes each in X, Y, and Z directions (JIS C60068-2-6-compliant, IEC60068-2-6-compliant)
Shock resistance	147m/s <sup>2</sup> (15G)/11ms/half-sine shock (JIS C 60068-2-27-compliant, IEC 60068-2-27-compliant)	
Standard	VCCI Class A, CE Marking (EMC Directive Class A, RoHS Directive), UKCA	

## Physical Dimensions

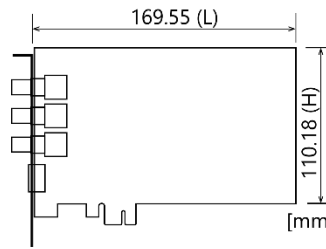

The standard outside dimension (L) is the distance from the end of the board to the outer surface of the slot cover.

## Optional Products

Product Name	Model type	Description
BNC Cable	BNC-B100	1m
	BNC-B200	2m
	BNC-B300	3m
Conversion Cable (16-Pin to 15-Pin) with Bracket	DT-E3	150mm
Shielded Cable with Connector on both sides for 15-pin D-Type Connector	PCB15PS-1.5P *1*2	1.5m
General Purpose Terminal (M3 x 15P)	FTP-15 *3	

- \*1 DT-E3 is required.
- \*2 It is required only when FTP-15 is used.
- \*3 DT-E3 and PCB15PS-1.5P optional cable is required separately.
- \* Visit the CONTEC website for the latest optional products.

## Connecting to an External Device

### Connecting an Interface Connector

To connect an external device to this product, plug the cable from the device into the interface connector (CN1, CN2, CN3, CN4, CN5) shown below.

Five interface connectors are available: for analog input (the CN2 and CN3 BNC connectors), for reference clock input (the CN4 BNC connector), for trigger input and status output (the CN1 6-pin terminal block connector), and for digital I/O signals (the CN5 16-pin pin header connector).

Interface Connector (CN5)

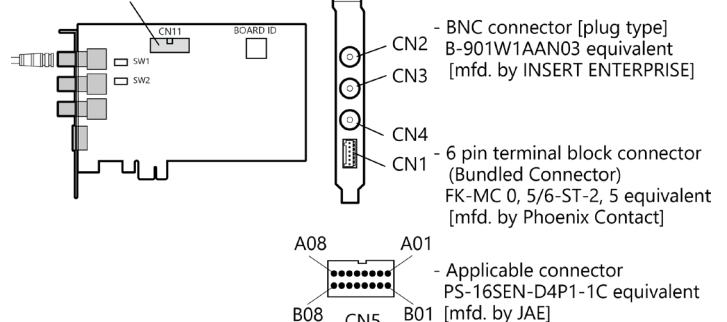

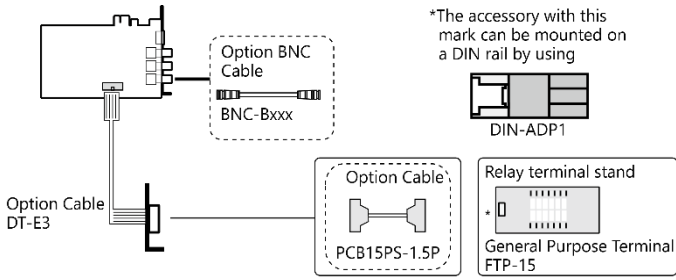

**Layout on the Interface Connector (CN2, CN3, CN4)**

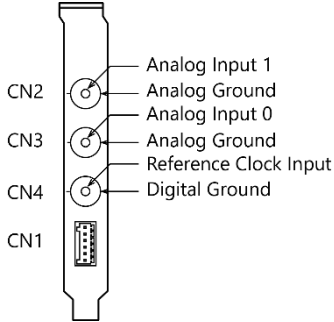

Signal name	Description
Analog Input0 - Analog Input1	Analog input signals. The numbers correspond to channel numbers.
Analog Ground	Analog ground common to analog input signals.
Reference Clock Input	Reference clock input signal.
Digital Ground	Digital ground common to digital input and output signals.

**CAUTION**

If analog and digital ground are shorted together, noise on the digital signals may affect the analog signals. Accordingly, analog and digital ground should be separated.

**Layout on the Interface Connector (CN1)**

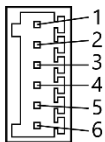

Pin Number	Signal name	Description
1	Digital Ground	Digital ground common to each signal.
2	External Start Trigger Input	External trigger input signal for sampling start conditions.
3	External Stop Trigger Input	External trigger input signal for sampling stop conditions.
4	Digital Ground	Digital ground common to each signal.
5	AI Status Output	Output the status signal.
6	Reserved	Connect nothing to this pin.

When connecting to this connector, use the included interface connector (connector plug) and wire each connecting cable.  
 [Applicable wire] : AWG26-20

**CAUTION**

- Do not connect any of the outputs to the analog or digital ground. Neither connect outputs to each other. Doing either can result in a fault.
- Disconnecting the interface connector by pulling on the cable may result in a broken wire. Be sure to hold onto the connector when disconnecting the interface connector.

**Layout on the Interface Connector (CN5)**

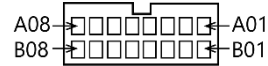

Pin Number	Signal name	Pin Number	Signal name
A01	Digital Output 0	B01	Digital Output 1
A02	Digital Output 2	B02	Digital Output 3
A03	Digital Ground	B03	Digital Input 0
A04	Digital Input 1	B04	Digital Input 2
A05	Digital Input 3	B05	Reserved
A06	Reserved	B06	Reserved
A07	AI Status Output	B07	Digital Ground
A08	N.C.	B08	N.C.

Signal name	Description
Digital Input 0 - Digital Input 3	Digital input signal.
Digital Out 0 - Digital Output 3	Digital output signal.
Reserved	Connect nothing to this pin.
AI Status Output	Output the status signal.
Digital Ground	Digital ground common to each signal.
N.C.	No connection to this pin.

**CAUTION**

Do not connect any of the outputs to the analog or digital ground. Neither connect outputs to each other. Doing either can result in a fault.

**Optional cable DT-E3**

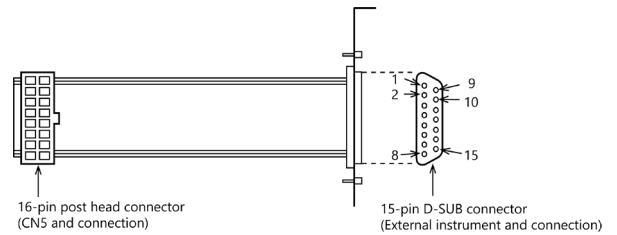

Pin Number	Signal name	Pin Number	Signal name
1	Digital Output 0	9	Digital Output 1
2	Digital Output 2	10	Digital Output 3
3	Digital Ground	11	Digital Input 0
4	Digital Input 1	12	Digital Input 2
5	Digital Input 3	13	Reserved
6	Reserved	14	Reserved
7	AI Status Output	15	Digital Ground
8	N.C.		

**Connecting Analog Input Signal**

This product uses single-ended input.

With single-ended input, the voltage of the input signal is indicated with the potential difference from analog ground.

**Single-ended Input**

The following figure shows an example of shielded cable connection. For the CN2, CN3 each analog input, connect the core wire to the signal line and connect the shielding to ground.

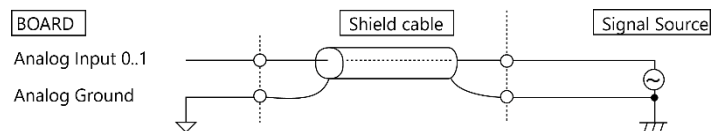

**CAUTION**

- Do not touch the external connector (BNC connector) when the power is on. Otherwise this may malfunction, cause a failure due to static electricity.

- If this product and the signal source receive noise or the distance between this product and the signal source is too long, data may not be input properly.
- The analog signal to be input should not exceed the maximum input voltage (based on this product analog ground). If it exceeds the maximum voltage, this product may be damaged.
- Input data remains indeterminate when no input pin is connected. The input pin for the channel not connected to the signal source must be connected to the analog ground.
- An input pin may fail to obtain input data normally when the signal source connected to the pin has high output impedance. If this is the case, change the signal source to one with lower output impedance or insert a high-speed amplifier buffer between the signal source and the analog input board to reduce the effect.

### Connecting Reference Clock Input Signals

This section provides an example of using a BNC cable to connect the reference clock input signal.

Use a BNC cable (BNC-Bxxx; sold separately) or a similar item to connect the external device that will output the reference clock to the CLK terminal. This input signal is a 3.3V, LVTTTL level signal.

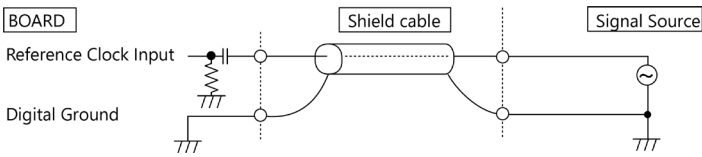

For the input conditions of the reference clock, see "Reference clock input" in "Hardware Specification".

#### CAUTION

- Do not touch the external connector (BNC connector) when the power is on. Otherwise this may malfunction, cause a failure due to static electricity.
- The reference clock input signal to be input should not exceed the maximum input voltage (based on this product analog ground). If it exceeds the maximum voltage, this product may be damaged.

### Connecting Digital I/O & Control Signals

Digital I/O signals can be used as control I/O signals (external trigger input signals, status output signals, etc.). The following section shows examples of how to connect signals.

User can use a 15-pin D-SUB connector with bracket (DT-E3) and to connect your external devices to CN5. When sampling is in operation, the "H" level is output in the external status output signal (AI Status Output terminal). When sampling is stopped, the "L" level is output in this signal.

External status output signal is an output in positive logic.

All the digital I/O signals and control signals are LVTTTL level signals.

#### Digital Input Connection

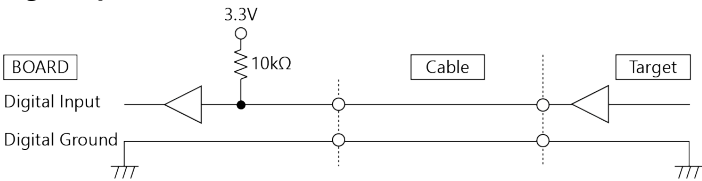

#### Digital Output Connection

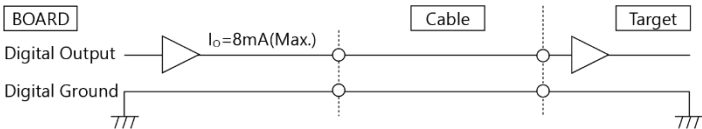

#### CAUTION

- Do not connect any output signal to the analog or digital ground. Do not interconnect outputs. Doing either can cause a malfunction.
- If connected to each output, a pull-up resistor must be about 10 kΩ to pull up with a 3.3V power source.
- Each input accepts 5V TTL signals.

### Circuit Block Diagram

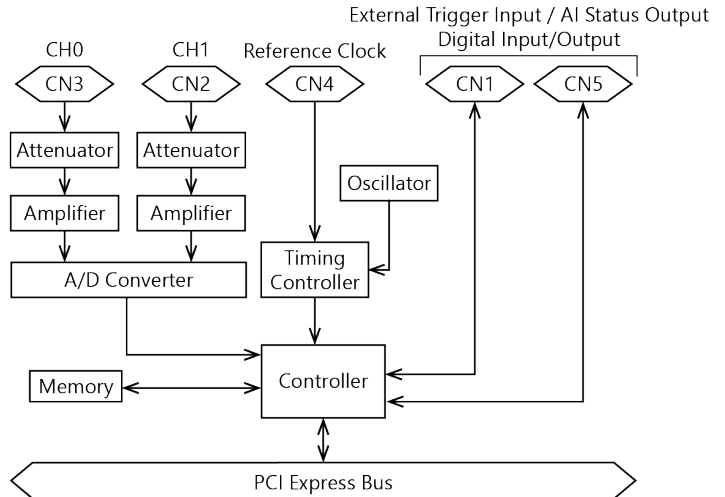

### Nomenclature of Product Components

Component names of the product are shown in the figure below.

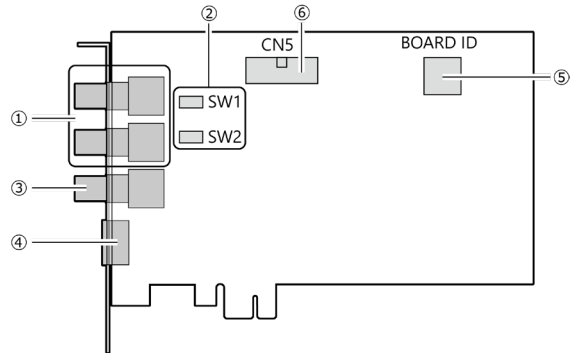

No.	Name	No.	Name
1	Connector for analog input signal	4	Connector for control signal
2	Termination register switch	5	Board ID Setting Switch
3	Connector for reference clock input	6	Connector for digital I/O signal