

USB I/O Unit – Module Type (4 slot) CC-USB271-CPSN4



* Specifications, color and design of the products are subject to change without notice.

Features

I/O module expansion

With this product, you can freely add I/O modules to match the necessary functions from among the varied collection of CONPROSYS nano series I/O modules.

Easy installation and removal of I/O modules

Expansion modules can be installed and removed without any tools.

USB Type-C port provided

The product has a USB Type-C port and can be operated by bus power from the host.

Compact Design

Compact design, 110 (W) × 74.8 (D) × 95 (H) mm, features flexibility in installation.

Applicable with Windows driver software

Applications can be created with Windows driver software in the Win32 API function format (DLL). On top of that, you can check whether software and hardware are operating properly with the diagnostic program.

Packing List

- Product...1
- Setup Guide...1
- Warranty Certificate...1
- Serial Number Label...1
- USB Cable [Type-A → Type-C, 1.8m]...1
- Blank panel...3(Attached to the product)
- Power Connector ...1(Attached to the product)
- Cable Attachment Fitting...1
- Screw for Cable Attachment Fitting...1
- Cable Tie...1

Support Software

You can use CONTEC support software according to your purpose and development environment. For more details on the supported OS, applicable languages, or to download the latest version of software, visit the CONTEC Web site.

Name	Contents	How to get
Driver software - API-DIO(WDM) - API-AIO(WDM) - API-CNT(WDM)	They are Windows driver software provided in the Win32 API function format (DLL). Various sample programs such as Visual Basic and Visual C++, etc and diagnostic program useful for checking operation are provided.	Download from the CONTEC website

This product is an I/O Unit (module type) which can be connected to a USB port on the PC to add input or output functions to your system. With this unit, you can freely add I/O modules to match the necessary functions from among the varied collection of CONPROSYS nano series I/O modules.

The product has a USB Type-C port and can be operated by bus power from the host.

- * The contents in this document are subject to change without notice.
- * Visit the CONTEC website to check the latest details in the document.
- * The information in the data sheets is as of February 2026.

Specifications

Function specifications

Item		Specification	
USB	Bus specification	USB specification 2.0/1.1 complied	
	USB transfer rate*1	12Mbps (full-speed), 480Mbps (high-speed)	
	Connector	Type-C USB connector	
Expansion slot	Number of slots	4	
	Maximum power supply	12 - 24V 200mA, 5V 250mA, 3.3V 200mA (per slot)	
	Number of insertions/removals	50 times (min)	
LED	PWR(Green) / RUN(Green) / STS(Green) / ERR(Red)		
Switch	Setting switches, USB selection switch		
Power supply *1	Rated input voltage	12 - 24VDC	
	Input voltage range	10.8 - 30VDC	
	Power consumption	<CPU Unit alone *2> Self-power 24V	0.05A (Max)
		Self-power 12V	0.11A (Max)
		Bus power 5V	0.24A (Max)
	Connector	2 pieces 3.5mm pitch 3-pin Terminal (V+, V-, FG)	
Applicable wire	AWG24 - 16		
Surge protection element V+ - V-, V- - FG	Interactive TVS Diode Stand off voltage: ±30V, Peak pulse power: 400W (1ms)		
Physical dimensions (mm)	110(W) x 74.8(D) x 95(H)mm (not include projection)		
Weight	250g		
Attached cable	USB cable 1.8m		
Installation method	Quick installation on a 35 mm DIN rail Vertical installation with screws *3		

*1 Use the power cable within 3meters

*2 With no USB load and no expansion slot load

*3 Commercially available screws are required.

Installation Environment Requirements

Item	Description
Operating ambient temperature	Vertical installation -20 +60°C Vertical installation with an angle of 90° to the right/left, Horizontal installation : -20 +50°C
Operating ambient humidity	10 - 90%RH (No condensation)
Non-operating ambient temperature	-20 +60°C
Non-operating ambient humidity	10 - 90%RH (No condensation)
Floating dust particles	Not to be excessive
Corrosive gases	None
Line-noise resistance	Line noise
	Static electricity resistance
Vibration resistance	Sweep resistance
	Shock resistance

Item	Description
Grounding	Class D grounding (previous class 3 grounding), SG-FG/ non-conduction
Standard	VCCI Class A, FCC Class A CE Marking (EMC Directive Class A, RoHS Directive), UKCA, ISED

- *4 When an optional power product is used.
- *5 When an optional power product is used : 10 - 55Hz (See the manual of optional power product for details)

About Current Consumption of Expansion Slots

The current consumption of this product varies depending on the current consumption of the installed I/O modules.

The maximum power consumption of the product itself (No I/O modules installed) when operated by bus power is 1.2 [W]. See the "Optional Products" for the power consumption of individual I/O modules.

When using the bus power connection, the available power amount to operate by bus power differs depending on the setting of the selection switch and the specification of the USB port on the PC. Make certain that the total consumed power of the product and installed I/O modules do not exceed the available amount of power supplied by bus power.

Connection to	USB Selection Switch	Available Power Amount to Operate by Bus Power
USB2.0 Type-A	USB2	2.25W
USB3.0 Type-A	USB3	4.05W
USB Type-C [1.5A-supported]	-	6W
USB Type-C [3.0A-supported]	-	12W

- *The bus power maximum amount includes cable loss.
- * Includes conversion loss during voltage conversion on the product.
- * The Type-C to Type-C USB cable is additionally required when connecting to Type-C.

An example)

When four CPSN-DI-08L modules are installed, the maximum power consumption is

$$1.2[W] + 0.3[W] \times 4 = 2.4[W]$$

Connecting to USB2.0 Type-A can supply the power only up to 2.25W so that it is insufficient for this setting.

It needs to be connected to USB3.0 Type-A or Type-C, or should be operated by self-power using an external power supply.

CAUTION

When you decide to use the type-C to Type-C USB cable, choose the cable that supports 3A outputs to meet the USB2.0 standard and USB Type-C standard. Using other cable type can result in errors or damages.

Physical Dimensions

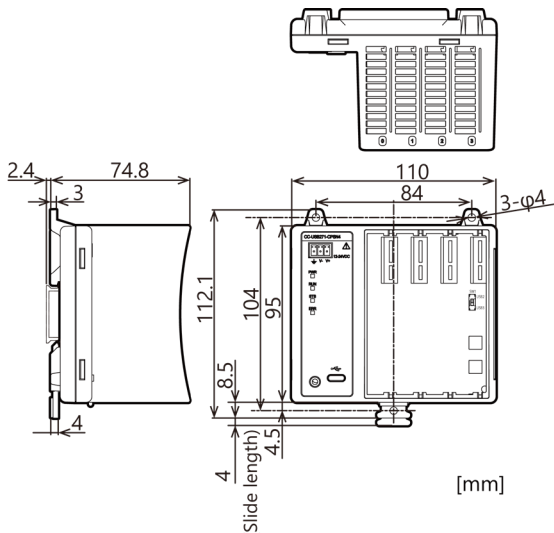

Name of each parts

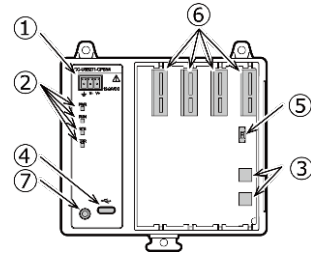

- (1) Power Supply Connector: This is a connector for power supply. (Use the 3-pin connector included in the package.)
- (2) LED Indicator: This is an LED to display the status of the product.
- (3) Setting Switches: Setting switches are used to distinguish units. Assign a unique ID per unit.
- (4) USB Port [Type-C]: This is a USB port for type-C.
- (5) USB Selection Switch: This is used to connect to either USB 2.0 or USB 3.0 of the USB port for type-A.
- (6) Expansion Slots: Slots are used to supply power to and communicate with expansion modules.
- (7) Setting Place for the Attachment Fitting: This is used to set the cable attachment fitting.

Power Supply Connector

Use the 3-pin connector, included in the package, to connect to external power. The product can also be operated by USB bus power without using an external power supply.

- Mounted Connector
3-pin European style terminal block (3.5mm pitch, 3 x 1 row)
MCV 1,5/3-G-3,5 P26 THR [Phoenix Contact] or equivalent
- Compatible Connector
3-pin European style terminal block (3.5mm pitch, 3 x 1 row)
FK-MCP 1,5/3-ST-3,5 [Phoenix Contact] or equivalent

Mark	Description
	Frame ground
V-	Power supply (GND)
V+	Power supply (12-24VDC)

USB Selection Switch

This product has a function (USB power shortage detection) to warn a power shortage with ERR LED flashing and stop operating the system if consumed power exceeds the available amount of power supplied from USB port on the PC when the Unit is run by bus power.

The function of USB power shortage detection can avoid errors caused by power shortages during the operation and stop supplying the power more than available amount from the USB port on the PC.

The available power amount differs depending on the USB port specification. Set the USB selection switch accordingly to detect power shortage appropriately. Connecting to the USB Type-C port on the PC disables the USB selection switch setting and the power shortage is detected automatically.

USB port on the connected PC	Available power amount from USB port	USB selection switch setting
USB2.0 Type-A	5V/0.5A	USB2
USB3.0 Type-A	5V/0.9A	USB3
USB Type-C [1.5A-supported]	5V/1.5A	- (Switch setting is disabled. Power shortage is automatically detected.)
USB Type-C [3.0A-supported]	5V/3.0A	- (Switch setting is disabled. Power shortage is automatically detected.)

CAUTION

When connecting to the USB2.0 Type-A port, the switch setting should be USB2. Even the USB port on the PC has no over-current protection, the function of USB power shortage detection can stop supplying the power exceeding 500mA, thereby protecting the USB port on the PC.

Optional Products

Optional product items are as follows:
Use these items with the main unit, as necessary.

DIN rail fitting power supply

Model type	Power Consumption*1	Driver Software	Description
CPS-PWD-30AW24-01	-	-	30W (Input: 100-240VDC, Output: 12VDC 1.3A)
CPS-PWD-90AW24-01	-	-	90W (Input: 100-240VDC, Output: 12VDC 3.8A)

*1 Includes conversion loss during voltage conversion on the product.

I/O module Digital input and output

Model type	Power Consumption*1	Driver Software	Description
CPSN-DI-08L	0.3W	API-DIO(WDM)	with isolated digital input (input 8 channels, sink input / source input)
CPSN-DI-08BL	1.1W		with isolated digital input (input 8 channels, sink input, built-in power supply)
CPSN-DI-08FCL	0.4W		with isolated digital input (input 8 channels, sink input, Synchronization function *2)
CPSN-DI-08FCRL	0.4W		with isolated digital input (input 8 channels, source input, Synchronization function *2)
CPSN-DI-16BCL	1.7W		with isolated digital input (input 16 channels, sink input / source input, built-in power supply)
CPSN-DIO-08SL	0.3W		with isolated digital input/output (input 8 channels, output 8 channels, sink)
CPSN-DO-08L	0.4W		with isolated digital output (output 8 channels, sink output)
CPSN-DO-08BL	1.5W		with isolated digital output (output 8 channels, sink output, built-in power supply)
CPSN-DO-08RL	0.4W		with isolated digital output (output 8 channels, source output)
CPSN-DO-08BRL	1.6W		with isolated digital output (output 8 channels, source output, built-in power supply)
CPSN-DO-08FPW	0.7W		with isolated digital output (output 8 channels, sink output / source output, Synchronization function *2)
CPSN-DO-16L	0.7W		with isolated digital output (output 16 channels, sink output)
CPSN-DO-16BL	1.4W		with isolated digital output (output 16 channels, sink output, built-in power supply)

*1 Includes conversion loss during voltage conversion on the product.
*2 For details on the synchronization function, refer to the Reference Manual (Hardware) for each module.

I/O module Relay

Model type	Power Consumption*1	Driver Software	Description
CPSN-RRY-4PCA	1.5W	API-DIO(WDM)	with relay contact output (4channels)

*1 Includes conversion loss during voltage conversion on the product.

I/O module Analog input

Model type	Power Consumption*1	Driver Software	Description
CPSN-AI-1208U	1.8W	API-AIO(WDM)	with isolated analog input (12-bit voltage input / current input, SE Input 8 channels / Differential Input 4 channels)
CPSN-AI-1604U	2.1W		with isolated analog input (16-bit voltage input / current input, Differential Input 4 channels)
CPSN-AI-2408U	1.4W		with isolated analog input (24-bit voltage input / current input, SE Input 8 channels / Differential Input 4channels)

*1 Includes conversion loss during voltage conversion on the product.

I/O module Analog output

Model type	Power Consumption*1	Driver Software	Description
CPSN-AO-1204U	1.9W	API-AIO(WDM)	with isolated analog output (12-bit voltage output / current output, 4 channels, Synchronization function *2)
CPSN-AO-1602LC	3.2W		with isolated analog output (16-bit voltage output / current output, 2 channels)
CPSN-AO-1602LC2	3.3W		with isolated analog output (16-bit voltage output / current output, 2 channels, Synchronization function *2)

*1 Includes conversion loss during voltage conversion on the product.
*2 For details on the synchronization function, refer to the Reference Manual (Hardware) for each module.

I/O module Counter

Model type	Power Consumption*1	Driver Software	Description
CPSN-CNT-3201I	0.4W	API-CNT(WDM)	with isolated counter input (32-bit, 1channel)
CPSN-CNT-3201I2	0.4W		with isolated counter input (32-bit, 1channel, Synchronization function *2)

*1 Includes conversion loss during voltage conversion on the product.
*2 For details on the synchronization function, refer to the Reference Manual (Hardware) for each module.

Visit the CONTEC website for the latest optional products.