

CONPROSYS nano Series
Analog Output Module
16bit DAC Channel Isolation
CPSN-AO-1602LC2



Features

Analog outputs with inter-channel isolation

Analog voltage output and analog current output with inter-channel isolation are equipped. Inter-channel isolation prevents interference between channels, therefore, the product can be used even when the ground levels of the device connected to each channel are different.

Supportable for various voltage output ranges and current output types

With the CPSN-AO-1602LC2, the output ranges of $\pm 10V$, $\pm 5V$, 0 to $+10V$, 0 to $+5V$, 0 to $+20mA$, and 4 to $+20mA$ can be switched by software command.

Synchronization function supported *1

The synchronization control function provided by the installed CPU unit is supported. You can control the timing of input and output according to the synchronization signal from the CPU unit, allowing for control and measurement that are aligned with the timing of the entire system.

No external power is required for current outputs

This product has the built-in power for current outputs, therefore, requires no external power supply.

Relay for controlling outputs

With the relay in the product, unstable output voltage/current, which often occurs when the CPU Unit is powered on, can be avoided. Since outputs from all the channels are performed through the relay, damages or errors of the connected devices can be prevented.

Easy installation and removal

This product can be installed in and removed from the CPU Unit without any tools.

Adaptable to a wide range of temperature between -20 and +60°C

The product is capable of operating in the temperature between -20 and $+60^{\circ}C$. It can be installed in the various environments.

No electrolytic capacitor

Without an electrolytic capacitor, which has a limited life, we are creating the product with a longer life.

*1 For details on whether functions can be used, refer to the CPU Unit Software Manual.

Packing List

- Product ...1
- 10-pin Connector...1 (attached to the product)
- Please read the following... 1

This product is an expansion I/O module that adds an analog output interface to the CPU Unit of the CONPROSYS nano series.

This product has analog outputs with 16-bit resolution of inter-channel isolation.

Voltage output 2ch and current output 2ch are switchable with one module.

- * Specifications, color and design of the products are subject to change without notice.
- * The contents in this document are subject to change without notice.
- * Visit the CONTEC website to check the latest details in the document.
- * The information in the data sheets is as of June, 2026.

Specifications

Function Specifications

Item	CPSN-AO-1602CL2
Output type	Inter-channel isolation Voltage Current Outputs
Output range	$\pm 10V$, $\pm 5V$, 0 - $+10V$, 0 - $+5V$, 0 - $+20mA$, 4 - $+20mA$ (Set by software command)
Maximum output current	$\pm 5mA$ (For voltage output)
Load resistor	100 - 600Ω (For current output)
Voltage output impedance	10Ω max.
Output channel	2ch
Resolution	16-bit
Non-Linearity error *1	For voltage : $\pm 20LSB(25^{\circ}C, 1-99\%FS, \text{no load})$ For current : $\pm 20LSB(25^{\circ}C, 1-99\%FS, \text{with } 250\Omega)$
Settling time *2	Voltage : $30\mu\text{sec}$ (no load) Current : $10\mu\text{sec}$ (with 250Ω)
Data buffer	-
Synchronization function	Supported *3
Isolation	Inter-channel isolation
Voltage resistance	$500VDC$
Connector	2 pieces 3.81mm pitch 10-pin terminal
Applicable wire	AWG28 - 16
LED	-
Electricity consumption	12 - $24V$ 0.16 - $0.08A$ (Max.) $3.3V$ $0.04A$ (Max.)
Physical dimensions (mm)	$15.6(W) \times 52.6(D) \times 84(H)$ (No projection included)
Weight	$50g$

*1 The non-linearity error means an error of approximately 0.18% occurs over the maximum range at $-20^{\circ}C$ and $60^{\circ}C$ ambient temperature.

*2 Settling time is from when data is set in DAC IC until the change of the analog value stops.

*3 For details on synchronization function, refer to the Reference Manual, "Description of Synchronization Function [CPSN-AO-1602LC2 only]."

Installation Environment Requirements

Item	Description	
Operating ambient temperature	-20 - $+60^{\circ}C$ (Wall installation at an angle of 0°) *1	
Operating ambient humidity	10 - $90\%RH$ (No condensation)	
Non-operating ambient temperature	-20 - $+60^{\circ}C$	
Non-operating ambient humidity	10 - $90\%RH$ (No condensation)	
Floating dust particles	Not to be excessive	
Corrosive gases	None	
Line-noise resistance	Line noise	Signal Line / $\pm 1kV$ (IEC61000-4-4 Level 3, EN61000-4-4 Level 3)
	Static electricity resistance	Touch / $\pm 4kV$ (IEC61000-4-2 Level 2, EN61000-4-2 Level 2) Air / $\pm 8kV$ (IEC61000-4-2 Level 3, EN61000-4-2 Level 3)
Vibration resistance	Sweep resistance	10 - $57Hz$ *2 / semi-amplitude vibration 0.15mm , 57 - $150Hz/2.0G$ 40minutes each in X, Y, and Z directions (JIS C 60068-2-6-compliant, IEC60068-2-6-compliant)
	Shock resistance	$15G$ half-sine shock for 11ms in X, Y, and Z directions (JIS C 60068-2-27 -compliant, IEC 60068-2-27 -compliant)
Standard	VCCI Class A, FCC Class A, CE Marking (EMC Directive Class A, RoHS Directive), UKCA, ISED	

*1 $-20^{\circ}C$ to $+45^{\circ}C$ with a vertical installation at an angle of 90° to the left/right, $-20^{\circ}C$ to $+50^{\circ}C$ for the horizontal installation.

*2 With the optional DIN rail fitting power supply: 10 - $55Hz$ (for details, see the User's Guide of the optional power supply).

Physical Dimensions

Physical dimensions of CPSN-AO-1602LC2

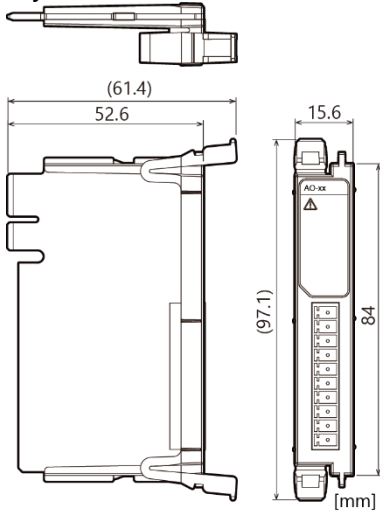

Physical dimensions of CPSN-AO-1602LC2 (with connector attached)

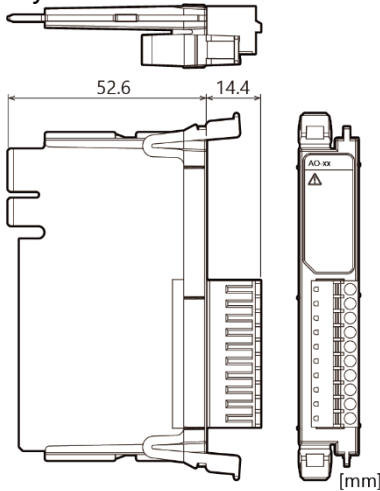

Name of each parts

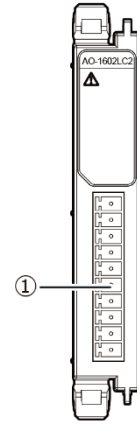

No.	Name	Function
1	Interface Connector	This is a connector for analog output. Use the 10-pin connector included in the package.

Interface Connector

This product has 2 channels of analog output. Use the 10-pin connector included in the package to connect to external power.

- Mounted Connector

10-pin European style terminal block (3.81mm pitch, 10 x 1 row)
MC 1.5/10-G-3,81 P26 THR [Phoenix Contact] or equivalent

- Compatible Connector

10-pin European style terminal block (3.81mm pitch, 10 x 1 row)
FK-MCP 1.5/10-ST-3,81 [Phoenix Contact] or equivalent

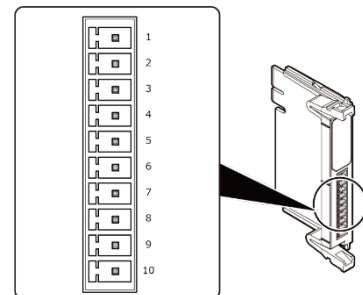

List of Options

Product Name	Model type	Description
CPU Unit *2	CPSN-MCB271-S1-041	Remote I/O CPU Unit *1
	CPSN-MCB271-1-041	Remote I/O CPU Unit LAN 2-channel model (4 slot) *1
	CPSN-MCB271-1-081	Remote I/O CPU Unit LAN 2-channel model (8 slot) *1
	CPSN-PCB271-S1-041	CODESYS Modbus Master CPU unit
	CPSN-EOB471EC-41	Remote I/O CPU Unit (EtherCAT, 4slot)
	CPSN-EOB471EC-81	Remote I/O CPU Unit (EtherCAT, 8slot)
	CPSN-EOB471EI-41	Remote I/O CPU unit (EtherNet/IP, 4slot)
	CPSN-EOB471EI-81	Remote I/O CPU unit (EtherNet/IP, 8slot)
USB I/O Unit - Module Type	CC-USB271-CPSN4	USB I/O Unit - Module Type (4 slot) *1
DIN rail fitting power supply	CPS-PWD-30AW24-01	Fitting power supply 30W (Input: 100 - 240VAC, Output: 24VDC 1.3 A)
	CPS-PWD-90AW24-01	Fitting power supply 90W (Input: 100 - 240VAC, Output: 24VDC 3.8 A)

*1 Available with our device driver API-TOOL.

*2 For the latest supported CPU units, see the Contec website.

* Visit the Contec website regarding information on the optional products.

Pin No.	Signal Name	Description
1	N.C.	No connection to this pin.
2	AO0	This indicates the analog output pin of channel 0.
3	AGND0	This indicates the ground pin for the analog output signals of channel 0.
4	N.C.	No connection to this pin.
5	AGND0	This indicates the ground pin for the analog output signals of channel 0.
6	N.C.	No connection to this pin.
7	AO1	This indicates the analog output pin of channel 1.
8	AGND1	This indicates the ground pin for the analog output signals of channel 1.
9	N.C.	No connection to this pin.
10	AGND1	This indicates the ground pin for the analog output signals of channel 1.

Cable

Use the analog output cable described below.

Cable	Use copper wires that withstand the temperature of 75 °C and higher.
Applicable wire	AWG28 - 16
Cable Length	Vary according to the environment where the product is used.

Analog Output Circuit

Output methods of analog signals are voltage outputs and current outputs. This section describes the example connections of each output method using a flat cable, a coaxial cable, and a shielded cable.

Voltage Output

[Connection using a flat cable]

The example below uses a flat cable to connect the product to an external device. For each analog output channel, connect the input of external device and ground on one-to-one basis.

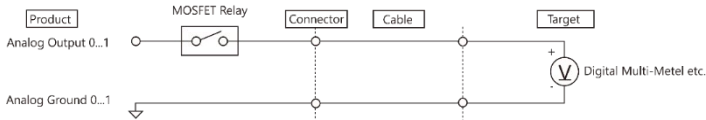

[Connection using a twisted cable]

The example below uses a twisted cable to connect the product to an external device. Use this type of cable if the external device is located at a distance from the product. For each analog output channel, connect the input of the external device and ground on one-to-one basis.

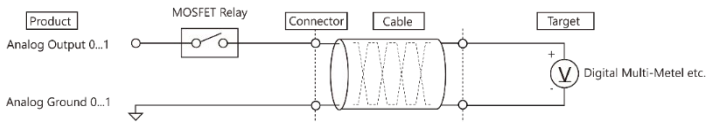

[Connection using a coaxial cable]

The example below uses a coaxial cable to connect the product to an external device. Use this type of cable if the external device is located at a distance from the product. For each analog output channel, connect the core wires to the input of the external device and connect the shielding to ground.

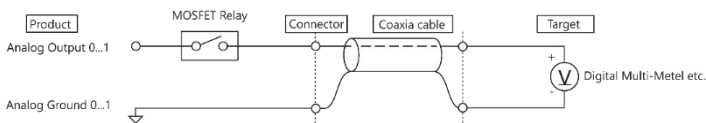

[Connection using a two-conductor twisted shield cable]

The example below uses a two-conductor twisted shield cable to connect the product to an external device. Use this type of cable if the external device is located at a distance from the product or if the connection requires higher noise immunity. For each analog output channel, connect the core wires to the input of the external device and to ground, connect the shielding to earth.

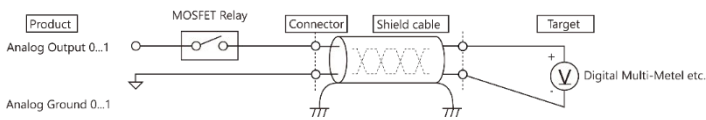

CAUTION

- Do not short-circuit voltage output signals and analog ground, as it may cause failure on the product.
- Do not connect voltage output signals to any other analog output, either on the product or on an external device, as it may cause failure on the product.
- To avoid any malfunction or damages, the connector plug should not be attached or detached when the power for the product or the external device is on.
- In situations where the connecting cable is subject to the effects of noise, the accurate voltage outputs can fail. The connecting cable should be installed away from any source of noise.
- The maximum current capacity for a voltage output signal is $\pm 5\text{mA}$. To avoid any malfunction, do not connect an external device that generates a load exceeding this range.
- In situations where the connecting cable is excessively long, the accurate voltage outputs can fail. The connection cable should therefore be within 1.5 meters.

Current Output

[Connection using a flat cable]

The example below uses a flat cable to connect the product to an external device. For each analog output channel, connect the positive side and the negative side of the external device on one-to-one basis.

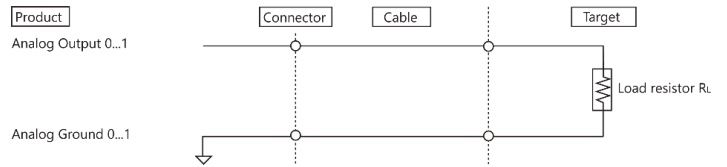

[Connection using a twisted cable]

The example below uses a twisted cable to connect the product to an external device. Use this type of cable if the external device is located at a distance from the product. For each analog output channel, connect the positive side and the negative side of the external device on one-to-one basis.

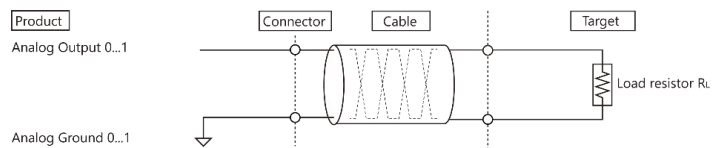

[Connection using a two-conductor twisted shield cable]

The example below uses a two-conductor twisted shield cable to connect the product to an external device. Use this type of cable if the external device is located at a distance from the product or if the connection requires higher noise immunity. For each analog output channel, connect the core wires to the external device and connect the shielding to ground.

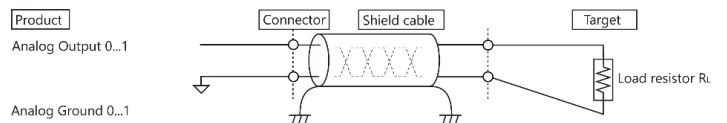

A connection example when current outputting with an external device.

[Connection with an external device of voltage inputs]

The current can be converted to voltage by connecting a shunt resistor to the external device for connecting with an external device of voltage inputs. 0 - 20mA can be converted to 0 - 5V when a 250Ω shunt resistor is used.

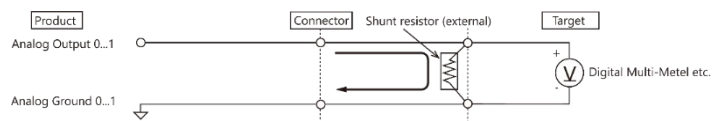

[Connection with more than one external device of current inputs]

When connecting with more than one external device of current inputs, the external devices can be connected in series. However, some external devices are unable to be connected for the following reasons.

- The total input impedance of the input device exceeds the maximum load resistance (600Ω) of this product.
- There is no potential difference (common) between the negative side of the input pin on the external device and the negative side of the power supply.

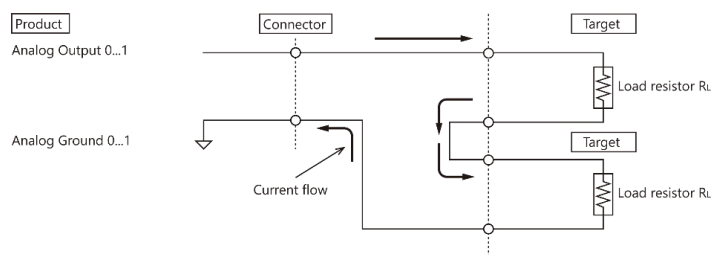

[Connection to an external device of current inputs with low input impedance]

This product is designed to operate with input impedance of between 100Ω and 600Ω. However, if the input impedance is low, the output accuracy might be affected by temperature, therefore it is recommended to use the product at 250Ω or higher.

When connecting to the device with 50Ω or 100Ω, for instance, make a dummy resistor connection and make the total of input impedance to be 250Ω to 600Ω.

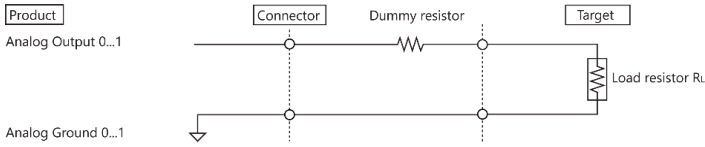

CAUTION

- Do not connect current output signals to any other analog output, either on the product or on an external device, as it may cause failure on the product.
- In situations where the connecting cable is subject to the effects of noise, the accurate current output can fail. The connecting cable should be installed away from any source of noise.
- To avoid any malfunction or damages, the connector plug should not be attached or detached when the power for the product or the external device is on.

Differences between this product and our earlier models

The CPSN-AO-1602LC2 is designed as a successor to the CPSN-AO-1602LC and can be used in the same way.

The differences between the CPSN-AO-1602LC2's specifications and those of the CPSN-AO-1602LC are shown below.

Differences between CPSN-AO-1602LC2 and CPSN-AO-1602LC

Item	CPSN-AO-1602LC2	CPSN-AO-1602LC
Output range	±10V, ±5V, 0 - +10V, 0 - +5V, 0 - +20mA, 4 - +20mA (Set by software command)	±10V, ±5V, 0 - +10V, 0 - +5V, 0 - +20mA (Set by software command)
Synchronization function	Supported	Not supported
Electricity consumption	12 - 24V 0.16 - 0.08A (Max) 3.3V 0.04A (Max)	12 - 24V 0.16 - 0.08A (Max) 3.3V 0.03A (Max)