

**CONPROSYS nano Series**  
**Relay Output Module 4ch**  
**CPSN-RRY-4PCA**



This product is an expansion I/O module that adds relay outputs (Contacts A) to the CPU unit of the CONPROSYS nano series.

Four channels of relay outputs are provided for one module.

- \* Specifications, color and design of the products are subject to change without notice.
- \* The contents in this document are subject to change without notice.
- \* Visit the CONTEC website to check the latest details in the document.
- \* The information in the data sheets is as of November 2024.

**Features**

**Independent Common Relay Outputs (Contacts A)**

Four channels of independent common relay outputs (form A) are provided. Independent common can support a different external power supply per channel (one common).

**Bus Isolated by Relays**

As Bus is isolated from the output interfaces by relays, this product has excellent noise performance.

**LED indicator for status check**

On/Off of the relay outputs can be visually checked with the LED indicator.

**Easy installation and removal**

This product can be installed in and removed from the CPU unit without any tools.

**Adaptable to a wide range of temperature between -20 and +60°C**

The product is capable of operating in the temperature between -20 and + 60°C. It can be installed in the various environments.

**No electrolytic capacitor**

Without an electrolytic capacitor, which has a limited life, we are creating the product with a longer life.

**List of Options**

Product Name	Model type	Description
CPU unit	CPSN-MCB271-S1-041	Remote I/O CPU unit
	CPSN-MCB271-1-041	Remote I/O CPU unit LAN 2-channel model
	CPSN-PCB271-S1-041	CODESYS Modbus Master CPU unit
USB I/O Unit - Module Type	CC-USB271-CPSN4	USB I/O Unit - Module Type (4 slot) *1
DIN rail fitting power supply	CPS-PWD-30AW24-01	Fitting power supply 30W (Input: 100 - 240VAC, Output: 24VDC 1.3 A)
	CPS-PWD-90AW24-01	Fitting power supply 90W (Input: 100 - 240VAC, Output: 24VDC 3.8 A)

\*1 Available with our device driver API-TOOL

\* Visit the Contec website regarding information on the optional products.

**Specifications**

Function specifications

Item		Description	
Output	Number of output signal channels	4 (Independent common)	
	Output format	Relay contacts (Form A) output	
	Operate time (ON)	Within 10ms	
	Release time (OFF)	Within 10ms	
	Contact resistance (Initial state) *1	75mΩ max.	
	Relay contact spec. *2*3	Rated load	125VAC 0.5A (resistive load), 30VDC 2A (resistive load)
		Maximum voltage	250VAC, 220VDC
Maximum current		2A	
Mechanical life expectancy		100 million operations min or more (Switching times : 36,000 operations/min)	
Electrical lifetime	100,000 operations min. (Switching times : 12,000 operations/min, with rated load)		
Isolation	Bus Isolated		
Dielectric strength voltage	10000 VAC		
Connector	2 pieces 3.81mm pitch 10-pin terminal		
Applicable wire	AWG28 - 16		
LED	4 (Green)		
Current consumption	5V 170mA (Max) 3.3V 20mA (Max)		
Physical dimensions (mm)	15.6(W)×52.6(D)×84(H) (No projection included)		
Weight	50g		

\*1 Does not include trace resistance and connector contact resistance.

\*2 Refer to "Maximum Switching Capacity" and use the product within the specified voltage and current range.

\*3 To meet CE Low Voltage Directive requirements, the rating should be up to 125VAC/0.5A (Load resistor), 110VDC/0.3A (Load resistor). Use the product within the specified ratings to satisfy these requirements.

**Packing List**

- Product ...1
- 10-pin connector...1
- Product Guide & Warranty Certificate...1, Install Guide
- Serial Number Label ...1

Installation Environment Requirements

Item		Description
Operating ambient temperature *4*5		-20 - +60°C (Wall installation) -20°C to +55°C with a vertical installation at an angle of 90° to the left/right or with a plane installation
Operating ambient humidity		10 - 85%RH (No condensation)
Non-operating ambient temperature		-20 - +60°C
Non-operating ambient humidity		10 - 85%RH (No condensation)
Floating dust particles		Not to be excessive
Corrosive gases		None
Line-noise resistance	Line noise	Signal Line /±1kV (IEC61000-4-4 Level 3, EN61000-4-4 Level 3)
	Static electricity resistance	Touch /±4kV (IEC61000-4-2 Level 2, EN61000-4-2 Level 2) Air /±8kV (IEC61000-4-2 Level 3, EN61000-4-2 Level 3)
	Vibration resistance	Module (excluding relay): 10 - 55Hz *6 / semi-amplitude vibration 0.15mm, 57 - 150Hz/2.0G 40minutes each in X, Y, and Z directions (JIS C60068-2-6-compliant, IEC60068-2-6-compliant) Relay: 10 - 55 - 10Hz / semi-amplitude vibration 1.65mm (double-amplitude vibration 3.3mm)
Shock resistance		Module (excluding relay): 15G half-sine shock for 11ms in X, Y, and Z directions (JIS C 60068-2-27 - compliant, IEC 60068-2-27 -compliant) Relay: 750m/s <sup>2</sup>
Standard		VCCI Class A, FCC Class A, CE Marking (EMC Directive Class A, Low Voltage Directive, RoHS Directive), UKCA, ISED

- \*4 There is a limit to the maximum current for relay contacts depending on the ambient temperature. Check the derating graph and use the product not to exceed the limit.
- \*5 Use the product within the specified temperatures to meet CE Low Voltage Directive requirements. (When the product is used at the specified Low Voltage Directive rating. Check the derating if using the product at a voltage/current lower than ratings)
  - Vertical installation : -20 to +60°C (when using DC or AC voltage)
  - Vertical installation at an angle of 90° to the right/left, or horizontal installation : -20 to +52°C (when using DC voltage), -20 to +50°C (when using AC voltage)
- \*6 With the optional DIN rail fitting power supply: 10 - 55Hz (for details, see the user's guide of the optional power supply)

Physical Dimensions

Physical dimensions of CPSN-RRY-4PCA

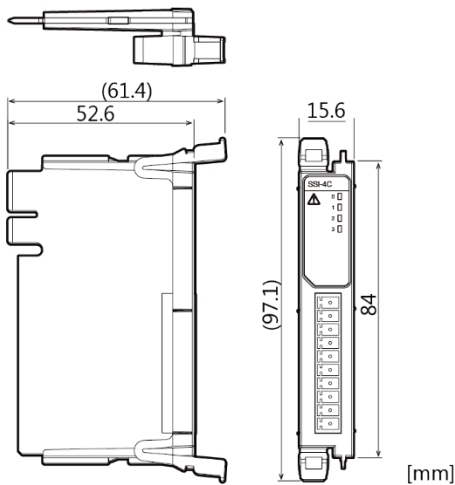

Physical dimensions of CPSN-RRY-4PCA (with connector attached)

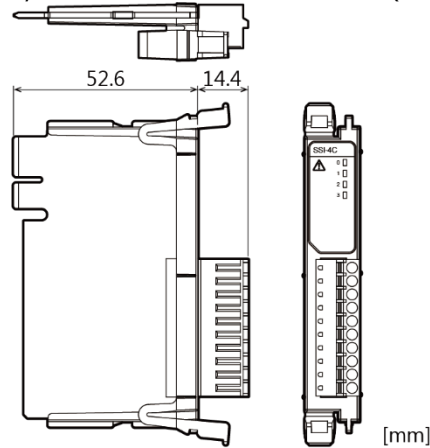

Name of each parts



- (1) LED Indicator : This indicates status of the product.
- (2) Interface Connector : Connector for Relay Output. Use the 10-pin connector included in the package.

Interface Connector

Four channels of thermocouple inputs are provided. Use the 10-pin connector included in the package.

- Mounted Connector  
10-pin European style terminal block (3.81mm pitch, 10 x 1 row)  
MC 1.5/10-G-3,81 P26 THR [Phoenix Contact] or equivalent
- Compatible Connector  
10-pin European style terminal block (3.81mm pitch, 10 x 1 row)  
FK-MCP 1.5/10-ST-3,81 [Phoenix Contact] or equivalent

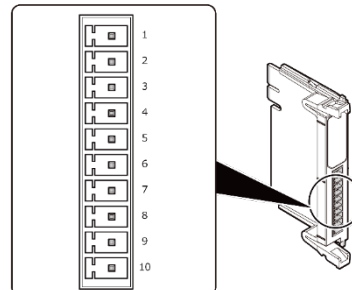

Pin No.	Signal Name	Description
1	N.C.	This pin is left unconnected.
2	NO0	This indicates the output signals (Normally open [NO]). It connects the input signals from the other devices.
3	COM0	This is a common terminal for output signals (Normally open [NO0]).
4	NO1	This indicates the output signals (Normally open [NO]). It connects the input signals from the other devices.
5	COM1	This is a common terminal for output signals (Normally open [NO1]).
6	N.C.	This pin is left unconnected.
7	NO2	This indicates the output signals (Normally open [NO]). It connects the input signals from the other devices.
8	COM2	This is a common terminal for output signals (Normally open [NO2]).

9	NO3	This indicates the output signals (Normally open [NO]). It connects the input signals from the other devices.
10	COM3	This is a common terminal for output signals (Normally open [NO3]).

**Cable**

Use the relay output cable described below.

Cable	Appropriate cable should be used to satisfy the user's environmental conditions.
Applicable wire	AWG28 - 16
Cable Length	The length differs depending on the actual use environment.

**Relay Output Circuit**

The signal outputs in the relay output circuits of the product are independent common relay outputs (Form A).

The rated load is 0.5A 125VAC (Resistive), 2A 30VDC (Resistive). Use the product within these ratings and not to exceed the voltage and current limits of the maximum switching capacity. To meet CE Low Voltage Directive requirements, the rating should be up to 125VAC/0.5A (Load resistor), 110VDC/0.3A (Load resistor). Use the product within the specified ratings to satisfy these requirements.

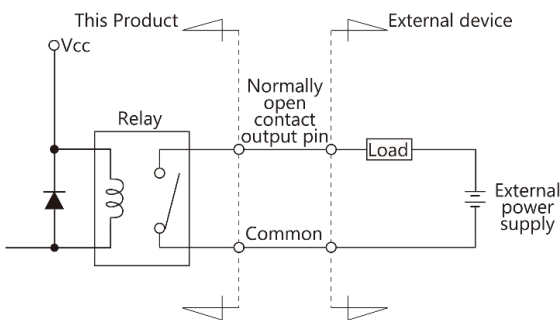

**Maximum Switching Capacity**

In the graph of the maximum value of switching capacity, you can read the maximum voltage and current that the relay can open and close. Use the product within the specified range of voltage and current.

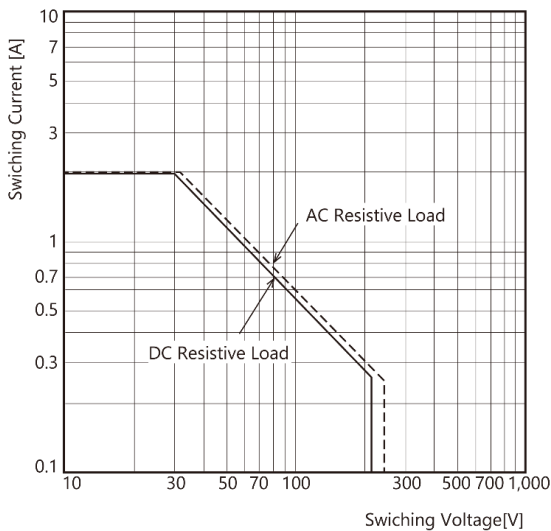

**Switching Current Derating due to the Ambient Temperature**

There is a limit to the current that can flow to the relay contacts depending on the ambient temperature. Use the product for the current contacts not to exceed the specified range.

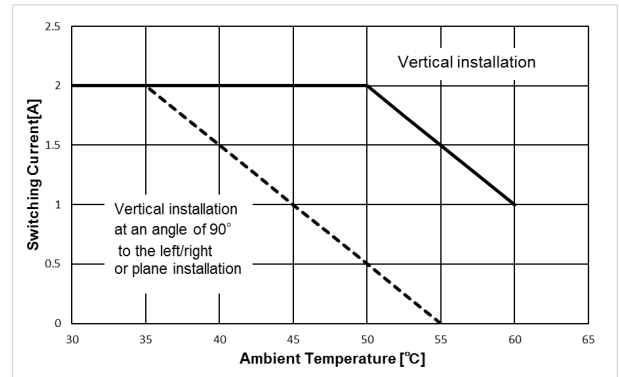

**CAUTION**

- The relay outputs are not activated (OFF) when the CPU unit is powered on.
- When the induction load is connected to relay, Open/Close switching capability of relay becomes lower than that of resistive load since the electromagnetic energy is stored in the induction load.
- Make sure that the relay is de-energized (relay OFF) in a system where the power is applied continuously for an extended period of time without Open/Close switching of relay. If the coil is energized for a long period (relay ON), the heat generated by the coil itself will accelerate the degradation of isolation and characteristics of the coil.
- If the frequency of Open/Close switching is less often than once a month, supply the power for the contacts and examine them periodically. When Open/Close switching of contacts are not conducted for a long period of time, contact may become unstable due to the formation of organic matters on the surface.