

Digital Input Terminal for USB2.0
DI-16TY2-USB



* Specifications, color and design of the products are subject to change without notice.

Features

Unisolated TTL level input

DI-16TY2-USB has the 16ch of unisolated TTL level input whose response speed is 200nsec.

Compatible to USB 2.0/USB1.1 and not necessary to power this product externally as the bus power is used

Compatible to USB 2.0/USB 1.1 and capable to achieve high speed transfer at High Speed (480 Mbps). Not necessary to power this product externally as the bus power of USB is used.

8 input signals can be used as interrupt request signals

You can use 8 input signals as interrupt request signals and also disable or enable the interrupt in bit units and select the edge of the input signals, at which to generate an interrupt.

Equipped with digital filter to prevent wrong recognition of input signals from carrying noise or a chattering

This product has a digital filter to prevent wrong recognition of input signals from carrying noise or a chattering. All input terminals can be added a digital filter, and the setting can be performed by software.

Surge absorption diodes are built in the input circuit for surge voltage protection

DI-16TY2-USB has a surge absorption diode connected to the +5V output pin at each input point to protect against surge voltages.

Easy-to-wire terminal connector adopted

Adoption of terminal connector (with screws) enables to achieve easy wiring.

Windows/Linux support device driver

Using the device driver API-TOOL makes it possible to create applications of Windows/Linux. In addition, a diagnostic program by which the operations of hardware can be checked is provided.

Functions and connectors are compatible with Digital Input Terminal for USB 2.0 DI-16TY-USB.

The functions same with Digital Input Terminal for USB 2.0 DI-16TY-USB is provided. In addition, as there is compatibility in terms of connector shape and pin assignments, it is easy to migrate from the existing system.

This product is a USB 2.0 compliant terminal that extends the digital signal input functions of a PC.

Being bus-powered, it does not need an external power supply.

DI-16TY2-USB has the 16ch of unisolated TTL level input. In addition, it uses a protection circuit (surge protection) as its Input circuit as well as an easily-wired terminal connector.

The DI-16TY2-USB has interrupt event function and digital filter function.

Windows/Linux device driver is supported with this product.

- * The contents in this document are subject to change without notice.
- * Visit the CONTEC website to check the latest details in the document.
- * The information in the data sheets is as of February, 2026.

Specifications

Function specification

Item		Specifications
Input	Type	TTL-level input (Negative logic *1)
	Number of Channels	16ch (8 channels available for interrupts *4) (1 common)
	Input resistance	10kΩ (1 TTL load)
	Interrupts *4	8 input signals are arranged into a single output of interrupt signal. An interrupt is generated at the falling (HIGH-to-LOW transition) or rising (LOW-to-HIGH transition) edge (set by software).
	Surge protector	ESD Noise-Clipping Diodes NNCD6.8J (NEC) or equivalent
	Response time	200nsec within *2
+ 5V output section	Output voltage	4.75 - 5.25V
	External supply capable current	5VDC 100mA (Max.)
	Surge protector	ESD Noise-Clipping Diodes NNCD6.8J (NEC) or equivalent
USB	Bus specification	USB Specification 2.0/1.1 standard
	USB transfer rate	12Mbps (Full-speed), 480Mbps (High-speed) *3
	Power supply	Bus power
Common	Allowable distance of signal extension	Approx. 1.5m (depending on wiring environment)
	Number of terminals used at the same time	16 terminals (Max.)
	Current consumption	5VDC 300mA (Max.)
	Physical dimensions (mm)	64(W) x 62(D) x 24(H) (exclusive of protrusions)
	Weight	70g (Not including the USB cable, attachment)
	Attached cable	USB cable 1.8m

- *1 Data "0" and "1" correspond to the High and Low levels, respectively.
- *2 The opto-coupler's response time comes.
- *3 This depends on the host PC environment used (OS and USB host controller).
- *4 The DI-16TY2-USB can use I-00 through I-07 as interrupt signals.

Installation Environment Requirements

Item	Specifications
Operating ambient temperature	0 - 50°C
Operating ambient humidity	10 - 90%RH (No condensation)
Floating dust particles	Not to be excessive
Corrosive gases	None
Standard	VCCI Class A, FCC Class A, CE Marking (EMC Directive Class A RoHS Directive), UKCA

Support Software

Name	Contents	How to get
Windows Version Digital I/O Driver software API-DIO(WDM)	The Windows device driver is provided as a form of Windows API functions. Various sample programs such as C# and Visual Basic .NET, Visual C++, Python etc. and diagnostic program useful for checking operation is provided.	Download from the CONTEC website *1
Linux Version Digital I/O Driver software API-DIO(LNX)	The Linux device driver is provided as a shared library. The software includes various sample programs such as gcc (C, C++) and Python programs, as well as a configuration tool to configure the device settings.	Download from the CONTEC website *1
Software Development Tool Kits (SDK) and Support Software	In addition to the device drivers, we offer many software programs for using CONTEC devices in an easier manner.	Download from the CONTEC website *2

*1 Download the files from the following URL.

<https://www.contec.com/download/>

*2 For supported software, search the CONTEC website for this product and view the product page.

<https://www.contec.com/>

Optional Products

Product Name	Model type	Description
14pin Screw Terminal Connector Set	CN6-Y14	6 pieces
Bracket for USB I/O Terminal products	BRK-USB-Y	

Visit the CONTEC website for the latest optional products.

Included Items

- Product [DI-16TY2-USB] ... 1
- Interface Connector Plugs ... 2
- USB Cable (1.8m) ... 1
- USB Cable Attachment ... 1
- Please read the following ... 1

Physical Dimensions

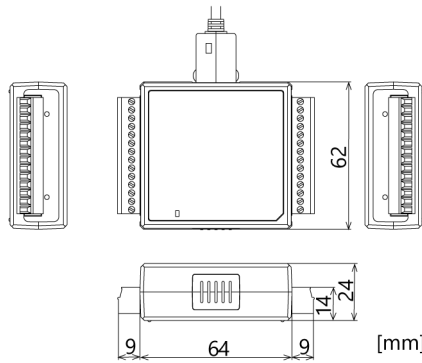

Component Name

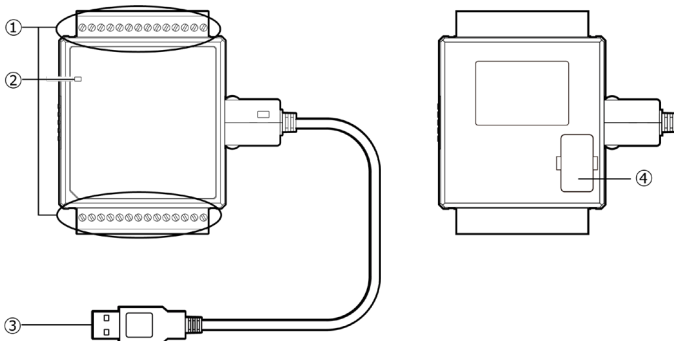

No.	Name	No.	Name
1	Interface Connector	3	USB Type-A connector
2	LINK Status	4	ID Setting Switch

LINK Status

Various communication statuses can be checked.

Name	Function	Indicator color	LED indicator
LINK Status	USB communication status	GREEN	ON : Communication established
	PC connection status		OFF : Communication unestablished
			ON : PC communication established
			OFF : PC communication unestablished

Circuit Block Diagram

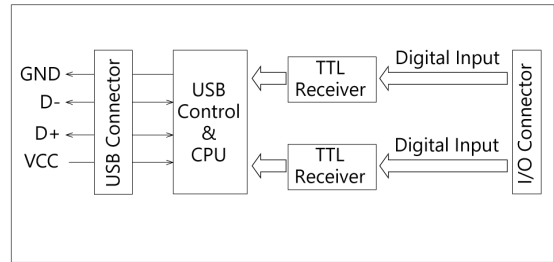

Layout on the Interface Connector

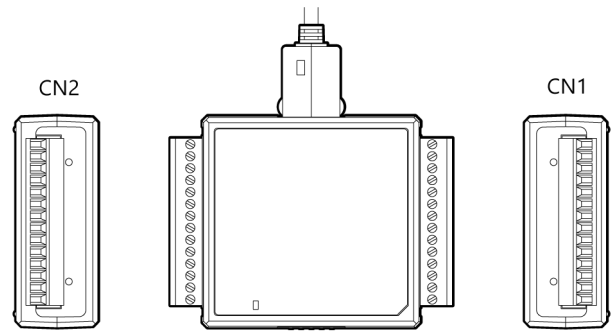

CN2		CN1	
GND	1	14	+5V
GND	2	13	+5V
FG	3	12	N.C.
I-07	4	11	I-10
I-06	5	10	I-11
I-05	6	9	I-12
I-04	7	8	I-13
I-03	8	7	I-14
I-02	9	6	I-15
I-01	10	5	I-16
I-00	11	4	I-17
N.C.	12	3	FG
+5V	13	2	GND
+5V	14	1	GND

* In DI-16TY2-USB, I-00 - I-07 can be used as interrupt signal.

Signal name	Description
I-00 - I-17	16 input signal pins. Connect output signals from the external device to these pins.
+5V	This pin outputs power at +5 V. Max. electrical current is 100mA.
GND	This pin is connected to the USB-pin's GND.
FG	This pin is connected to the Frame Ground of PC.
N.C.	These pins are left unconnected.

Connecting Input Signals

Input Circuit

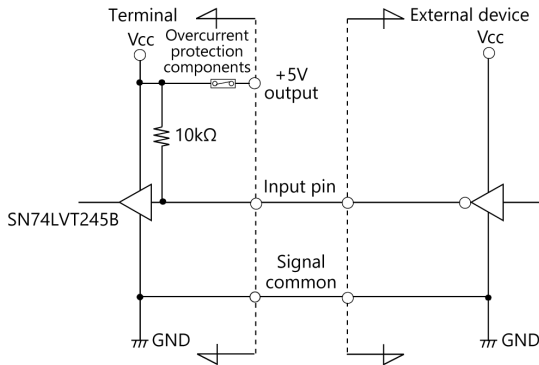

* I-xx represent an input pin.
 * One PolySwitch is connected to all of the +5V output pins.

External digital signals given to signal inputs are TTL levels. The individual input signals are passed to the personal computer as active low signals. As each of the signal inputs is pulled up internally, the output of a relay contact or semiconductor switch can be connected directly between the signal input and the signal common pin. Surge absorption diodes are connected to the input circuit.

Connecting a Switch

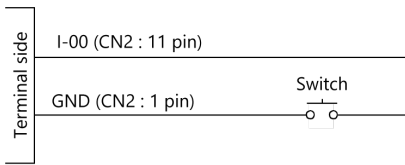

When the switch is ON, the corresponding bit contains 1.
 When the switch is OFF, by contrast, the bit contains 0.

Differences between this product and our earlier models

When two or more devices of the same product are connected to the same PC, the method of individual recognition differs from the conventional product. For this product, use the rotary switch on the bottom of the unit to select the device ID.

Item	Conventional product	This Product
Individual recognition method	Built-in ID	Set with the rotary switch
Interrupt event function	No	Yes
Digital filter function	No	Yes



How to open the cover

Use a flathead screwdriver or similar to open the cover on the underside of the product. This exposes the setting switches to set the device ID. As shown in Figure below, an easy way to open the cover is to insert the tip of the screwdriver into the slot and then rotate the screwdriver.

