

## N Series for USB Isolated Digital I/O Unit (16ch DI, 16ch DO) DIO-1616LN-USB



\* Specifications, color and design of the products are subject to change without notice.

### Features

- **16 channels of Opto-coupler isolated inputs (compatible with current sink and current source outputs) and 16 channels of Opto-coupler isolated open-collector outputs (compatible with current sink type)**

This product has the 16 channels of Opto-coupler isolated inputs (compatible with current sink and current source outputs) and 16 channels of Opto-coupler isolated open-collector outputs (current sink type) whose response time is 200μsec.

Common terminal provided per 8 channels, capable of supporting a different external power supply. Supporting driver voltages of 12 - 24 VDC for I/O. The digital input can be checked with the LED indicator.

- **Opto-coupler bus isolation**

As the USB (PC) is isolated from the input and output interfaces by Opto-couplers, this product has excellent noise performance.

- **8 input signals can be used as interrupt request signals**

You can use 8 input signals as interrupt request signals and also disable or enable the interrupt in bit units and select the edge of the input signals, at which to generate an interrupt.

- **Equipped with digital filter to prevent wrong recognition of input signals from carrying noise or a chattering**

This product has a digital filter to prevent wrong recognition of input signals from carrying noise or a chattering. All input terminals can be added a digital filter, and the setting can be performed by software.

- **Zener diode for surge voltage protection and the circuit for overcurrent protection**

Zener diodes are connected to the output circuits to protect against surge voltages. In addition, the output circuit, it attaches the overcurrent protection circuit at the output 8-channel unit. The output rating is max. 60VDC, 100mA per channel.

- **Operation with USB bus power/12 - 24VDC power supply**

As the product can operate with USB bus power, power supply from the external source is unnecessary. Operation with a wide range power supply of 12 - 24 VDC is also available when the

This product is an USB 2.0-compliant digital I/O unit that provides the input and output function of digital signal from the USB port of PC. Digital signals can be input and output at 12 - 24VDC.

16 channels of Opto-coupler isolated inputs (compatible with both current sink and current source outputs) and 16 channels of Opto-coupler isolated open-collector outputs (compatible with current sink type) are equipped. Up to eight channels are used as an interrupt. Also, including a digital filter function which prevents wrong recognition of input signals, and output transistor protection circuit (surge voltage protection and over current protection).

Compact design not restricting installation location (188.0(W) x 78.0(D) x 30.5(H)) makes it easy to install the product within the panel or device using DIN rail mounting jigs, or on the floor or wall.

Windows/Linux device driver is supported with this product.

\*The contents in this document are subject to change without notice.

\*Visit the CONTEC website to check the latest details in the document.

\*The information in the data sheets is as of February, 2026.

product is used such as with a laptop computer to save power consumption or when the environment requiring a separate power supply, such as using a non-power connected USB hub. Therefore, it can be used in various equipment configuration and power supply environment. In addition, the FG terminal is equipped in the power connector.

- **Compact design not restricting installation location (188.0(W)×78.0(D)×30.5(H))**

Compact design of 188.0(W) x 78.0(D) x 30.5(H) does not require special installation location.

- **Compatible to USB 2.0/USB 1.1**

Compatible to USB 2.0/USB 1.1 and capable to achieve high speed transfer at High Speed (480 Mbps)

- **Diverse installations such as screw fastening, magnet (optional purchase), DIN rail are possible**

Installation on the floor / wall /ceiling is possible by screw fastening, with magnets (optional purchase), rubber feet, etc.

In addition, DIN rail mounting mechanism is equipped as standard with the product, making it easy to install the product within the panel or the device.

- **Easy-to-wire terminal connector adopted**

Adoption of terminal connector (with screws) enables to achieve easy wiring.

- **Windows/Linux support device driver**

Using the device driver API-TOOL makes it possible to create applications of Windows/Linux. In addition, a diagnostic program by which the operations of hardware can be checked is provided.

### Included Items

Product...1

Interface Connector...4

USB Cable Attachment on the main unit's side (For Mini B connector side)...1

Rubber feet...4

Please read the following...1

## Hardware specifications

### Function Specifications

Item		Specifications	
Input	Type	Opto-Isolated Input (compatible with current sink output and current source output)(Negative logic *1)	
	Number of Channels	16 channels (8 channels available for interrupts) (8 channels / common)	
	Input resistance	15kΩ	
	Current required to turn ON	0.7mA or more	
	Current required to turn OFF	0.15mA or less	
	Interrupts	8 input signals are arranged into a single output of interrupt signal An interrupt is generated at the falling (HIGH-to-LOW transition) or rising (LOW-to-HIGH transition) edge (set by software).	
	Response time	200μsec within *2	
Output	Type	Opto-isolated open collector output (Compatible with current sink)(Negative logic *1)	
	Number of Channels	16 channels (8 channels share 1 common)	
	Output rating	Output rated voltage	60VDC (Max.)
		Output rated current	100mA/channel (Max.)
	Residual voltage with output on	0.5V or less (Output current ≤ 50mA), 1.0V or less (Output current ≤ 100mA)	
	Surge protector	Zener diode CMZB68(TOSHIBA) or equivalent	
	Response time	Within 200μsec *2	
USB section	Bus specification	USB Specification 2.0/1.1standard	
	USB transfer rate	12Mbps (Full-speed), 480Mbps (High-speed) *3	
	Power supply	Bus power / Self-power *4	
Common	Allowable distance of signal extension	Approx. 50m (depending on wiring environment)	
	Isolated voltage	1000Vrms	
	External circuit power supply *5	12 - 24VDC(±10%)	
	Current consumption	12VDC 200mA (Max.), 24VDC 100mA (Max.)	
	Physical dimensions (mm)	188.0(W)×78.0(D)×30.5(H) (No protrusions)	
	Weight	300g (Not including the USB cable, attachment, connector)	
	Attached cable	USB cable 1.8m	

- \*1 Data "0" and "1" correspond to the High and Low levels, respectively.
- \*2 The Optocoupler's response time comes.
- \*3 This depends on the PC environment used (OS and USB host controller).
- \*4 The product can be operated with both Bus power and Self-powered.
- \*5 External circuit power supply is required.

### Installation Environment Requirements

Item	Specifications
Operating ambient temperature *1	0 - +60°C
Operating ambient humidity *1	10 - 90%RH (No condensation)
Floating dust particles	Not to be excessive
Corrosive gases	None
Standard	VCCI Class A, CE Marking (EMC Directive Class A, RoHS Directive), UKCA

- \*1 To suppress the heating, ensure that there are spaces for ventilation (about 5cm) around this product.

## Physical Dimensions

### Physical dimensions

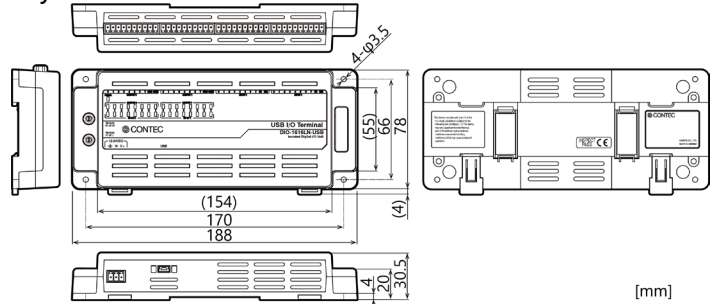

## Support Software

Name	Contents	How to get
Windows Version Digital I/O Driver software API-DIO(WDM)	T The Windows device driver is provided as a form of Windows API functions. Various sample programs such as C# and Visual Basic .NET, Visual C++, Python etc. and diagnostic program useful for checking operation is provided.	Download from the CONTEC website *1
Linux Version Digital I/O Driver software API-DIO(LNX)	The Linux device driver is provided as a shared library. The software includes various sample programs such as gcc (C, C++) and Python programs, as well as a configuration tool to configure the device settings.	Download from the CONTEC website *1
Software Development Tool Kits (SDK) and Support Software	In addition to the device drivers, we offer many software programs for using CONTEC devices in an easier manner.	Download from the CONTEC website *2

- \*1 Download the files from the following URL.  
<https://www.contec.com/download/>
- \*2 For supported software, search the CONTEC website for this product and view the product page.  
<https://www.contec.com/>

## Option

Product Name	Model type	Description
AC-DC Power Adaptor (12VDC, 1A)	POA201-10-2	
CONPROSYS Series Magnet (Four Piece Set)	CPS-MAG01-4	

Visit the CONTEC website for the latest optional products.

## Block Diagram

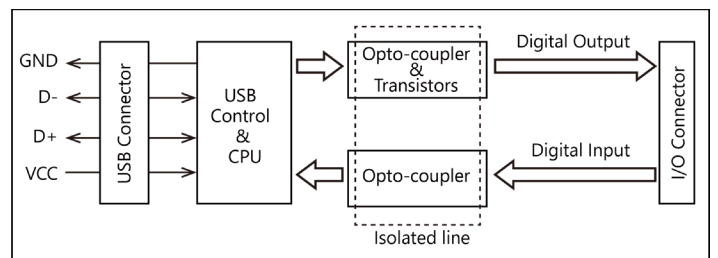

## Connecting an Interface Connector

Use the supplied interface connector (plug connector) to connect the product to an external device. The following example describes how to make the connecting cable with the interface connector (connector plug).

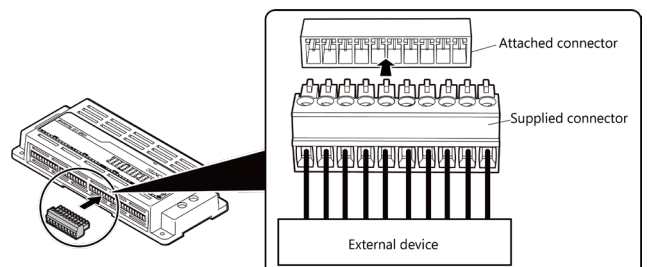

[Attached connector]: European type terminal 3.5 pitch 10-pin jack connector  
 [Supplied connector]: European type terminal 3.5 pitch 10-pin plug connector  
 [Compatible cable]: AWG28 - 16

**CAUTION**

- Removing the connector plug by grasping the cable can break the wire. Always grasp the interface connector to remove it.
- Do not set or remove the interface connector when the power is on or during the communication.

**Layout on the Interface Connector**

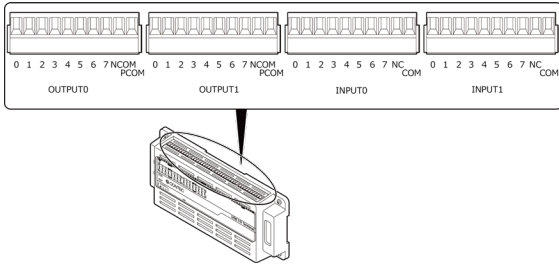

Connector name	Pin No.	Signal Name	Meaning	Connector name	Pin No.	Signal Name	Meaning
OUTPUT0	0	OUT00	+2 port (output)	INPUT0	0	IN00	+0 port (input)
	1	OUT01			1	IN01	
	2	OUT02			2	IN02	
	3	OUT03			3	IN03	
	4	OUT04			4	IN04	
	5	OUT05			5	IN05	
	6	OUT06			6	IN06	
7	OUT07	7	IN07				
	NCOM	COM0(-)	Common minus pin for +2 ports	NC	N.C.	Not Connected	
	PCOM	COM0(+)	Common plus pin for +2 ports	COM	COM	Common plus / minus pin for +0 ports	
OUTPUT1	0	OUT10	+3 port (output)	INPUT1	0	IN10	+1 port (input)
	1	OUT11			1	IN11	
	2	OUT12			2	IN12	
	3	OUT13			3	IN13	
	4	OUT14			4	IN14	
	5	OUT15			5	IN15	
	6	OUT16			6	IN16	
7	OUT17	7	IN17				
	NCOM	COM1(-)	Common minus pin for +3 ports	NC	N.C.	Not Connected	
	PCOM	COM1(+)	Common plus pin for +3 ports	COM	COM	Common plus / minus pin for +1 ports	

<b>IN00 - IN17</b>	16 input signal pins. Connect output signals from the external device to these pins.
<b>OUT00 - OUT17</b>	16 output signal pins. Connect these pins to the input signal pins of the external device.
<b>N.C.</b>	This pin is left unconnected.
<b>COM</b>	Common pins for 8 input signals. These pins are common to positive or negative side of external signals.
<b>COM0(-) - COM1(-)</b>	Common pins for 8 output signals. These pins are common to negative side of external signals.
<b>COM0(+)- COM1(+)</b>	Common pins for 8 output signals. These pins are common to positive side of external signals.

**CAUTION**

To perform input/output using this product with the CONTEC device driver, specify logical ports and logical bits when calling each function. For details, refer to the "Relationships between API-TOOL Logical Ports/Bits and Connector Signal Pins".

**Connecting Digital I/O Signals**

**Input Circuit**

Connect the input signals to a device which can be current-driven, such as a switch or transistor output device. The product inputs the ON/OFF state of the current-driven device as a digital value.

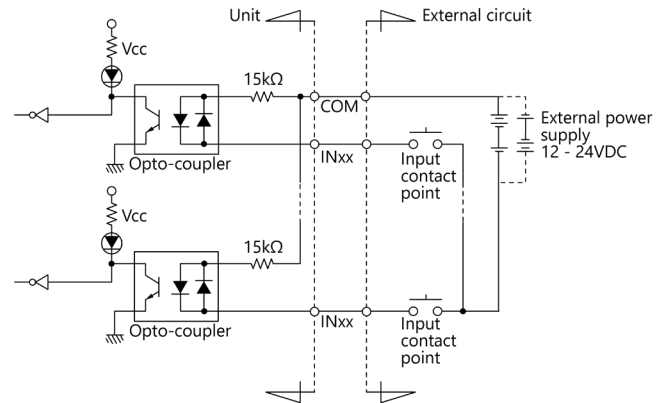

The signal input section consists of an Opto-coupler isolated input (compatible with both current sink output and current source output). An external power supply is therefore required to drive the input section of this product. The power requirement for this product is about 0.8 mA per input channel at 12VDC (about 1.6 mA at 24VDC).

**Example of Connection (An Example to use Bit0 of INPUT0)**

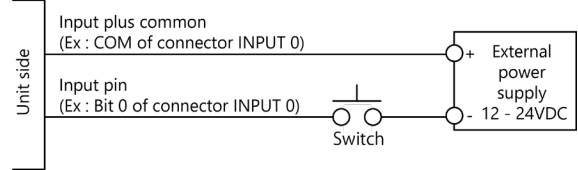

**Examples of Connection to an External Device (Example of a Connection between Input and Current Sink Output)**

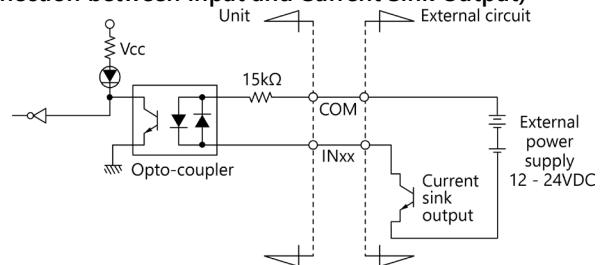

**Examples of Connection to an External Device (Example of a Connection between Input and Current Source Output)**

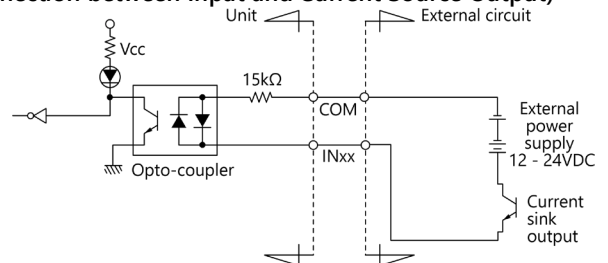

**Output Circuit**

Connect the output signals to a current-driven controlled device such as a relay or LED. The product controls turning on/off the current-driven controlled device using a digital value.

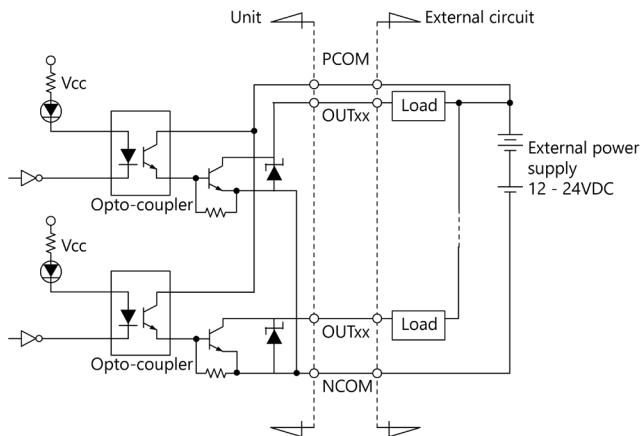

The signal output section consists of an Optocoupler isolated open collector output (current sink type). An external power supply is therefore required to drive the output section of this product. The maximum output current rating per channel is 100 mA for the product. As low saturation is used for outputting, connecting with TTL level input is also possible. When outputting is on, residual voltages (low level voltage) between the collector and emitter are 0.5V or less at output current 50mA, and 1.0V or less at output current 100mA. Zener diodes are connected to the output circuits to protect against surge voltages. Similarly, Over-current protection circuits are fitted to each group of 8channels outputs.

**CAUTION**

When the PC is turned on, all outputs are reset to OFF.

**Connection to the LED(An Example to use Bit0 of OUTPUT0)**

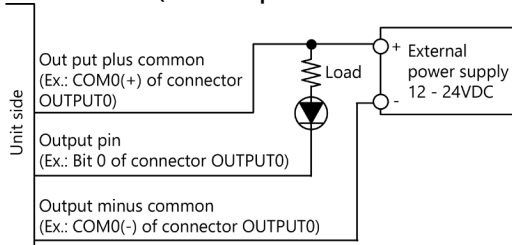

**Example of Connection to TTL Level Input(Connection Example of Output and TTL level Input Signal)**

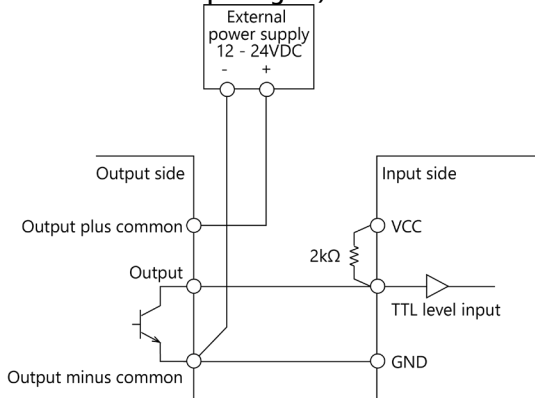

**How to connect between output (sink type) and input (compatible with sink output)**

Figure below shows the example of a connection between output (sink type) and input (compatible with sink output). See this example when connecting the device to the product.

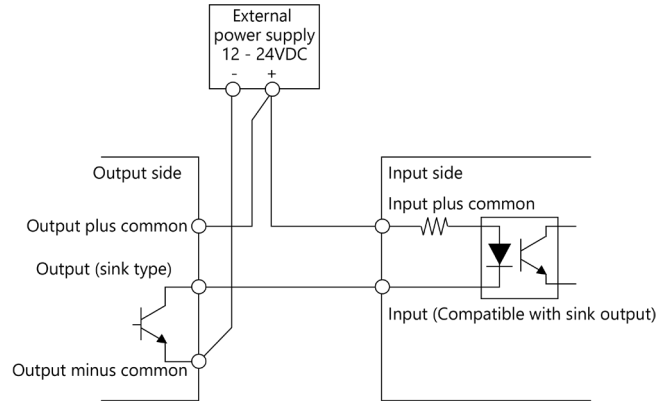

**Connecting with external power to drive the product**

This product can operate by connecting USB cable (bus power). In this case, power supply from an external source is unnecessary. However, when the product is used in the environment requiring a separate power supply such as using a laptop computer driven by battery that needs to save power consumption, or using a non-power connected USB hub, operation by connecting with the external power (self-powered) is available. To use the product by self-powered, use the power connector and connect with the external power source.

**Pin assignment**

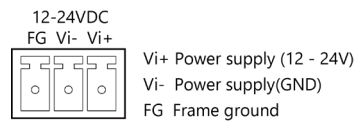

**Connecting power connector and the connector to be used**

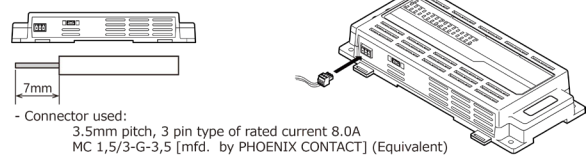

- Connector used: 3.5mm pitch, 3 pin type of rated current 8.0A
- MC 1,5/3-G-3,5 [mfd. by PHOENIX CONTACT] (Equivalent)
- Compatible plug: MC 1,5/3-ST-3,5 [mfd. by PHOENIX CONTACT] (Equivalent)
- Compatible wires : AWG28-16

Input terminal is 12 - 24VDC plus or minus 10 percentages input and the connector to be used is MC 1,5/ 3-G-3,5[PHOENIX CONTACT] (or equivalent). When supplying power with an applicable connector plug MC 1,5/3-ST-3,5[PHOENIX CONTACT] (or equivalent), strip off of the covered part of an appropriate cable and inset it into the connector plug, then, screw it firmly. The above applies to when connecting FG pin to the ground (earth).

When using an optional AC adapter [POA201-10-2], connect the adapter as is, into the power input connector. In addition, when the product is used in the overly noisy environment, connect FG pin to the ground (earth).

## AC adapter [POA201-10-2] connection

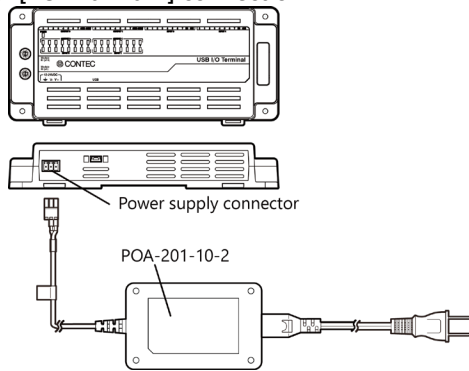

### ⚠ CAUTION

- Request input power specification of the product: 12 - 24VDC plus or minus 10 percentages, 0.2 - 0.1A (Max.)
- First, connect 12 - 24VDC power to the product, then connect USB cable to the PC. Do not turn on or off the 12 - 24VDC power during the operation. When unplugging, first unplug USB cable, then remove the 12 - 24VDC power.
- Do not set or remove the connector into the power input connector when the power is on.
- Do not plug or unplug the 12-24VDC power with the product while the 12-24VDC is outputting.
- Leave the AC adapter unplugged when the product is not in used.
- Continuously using the AC adapter heated affects its life.
- Use the AC adapter not in a closed place but in a well-ventilated place not to be heated.
- Do not remove the power connector [MC1,5/3-ST-3,5] that is attached to the AC adapter.
- When operating by either bus power or self-powered, connect FG pin to the ground (earth) if the product is used in the overly noisy environment.
- Inrush current may occur when the product is run by bus power. In this case, your PC might detect over-current so that it does not identify the product as a USB device. Use self-powered for that matter.