

Digital I/O board for PCI Express
DIO-3232T-PE



* Specifications, color and design of the products are subject to change without notice.

Features

Non-isolated TTL level input, non-isolated open-collector output
 DIO-3232T-PE has the 32ch of non-isolated TTL level input and 32ch of non-isolated open-collector output whose response time is 200nsec. The output rating is max. 30VDC, 40mA per ch.

32 input signals can be used as interrupt request signals
 You can use 32 input signals as interrupt request signals and also disable or enable the interrupt in bit units and select the edge of the input signals, at which to generate an interrupt.

Equipped with digital filter to prevent wrong recognition of input signals from carrying noise or a chattering
 This product has a digital filter to prevent wrong recognition of input signals from carrying noise or a chattering. All input terminals can be added a digital filter, and the setting can be performed by software.

Windows/Linux support device driver
 Using the device driver API-TOOL makes it possible to create applications of Windows/Linux. In addition, a diagnostic program by which the operations of hardware can be checked is provided.

Functions and connectors are compatible with PCI compatible board PIO-32/32T(PCI)H
 DIO-3232T-PE : The functions same with PCI compatible board PIO-32/32T(PCI)H are provided.

In addition, as there is compatibility in terms of connector shape and pin assignments, it is easy to migrate from the existing system.

Packing List

Product...1
 Please read the following...1

Physical Dimensions

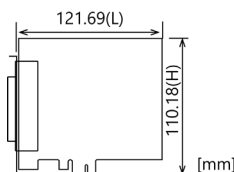

The standard outside dimension (L) is the distance from the end of the card to the outer surface of the slot cover.

This product is a PCI Express bus-compliant interface board for input/output of digital signals.

DIO-3232T-PE features 32 non-isolated TTL level inputs and 32 non-isolated open-collector outputs. You can use all of input signals as interrupt inputs. In addition, the digital filter function to prevent wrong recognition of input signals is provided.

Windows/Linux device driver is supported with this product.

- * The contents in this document are subject to change without notice.
- * Visit the CONTEC website to check the latest details in the document.
- * The information in the data sheets is as of May, 2026.

Specifications

Function specification

Item		Specifications
Input	Type	Non-isolated TTL-Level Input (Negative logic *1)
	Number of Channels	32 channels (all available for interrupts) (1 common)
	Input resistance	10kΩ
	Interrupts	Combine 32 interrupt signals to one interrupt request signal as the INTA. Either rising edge or falling edge of input signal can generate interrupt.
	Response time	200nsec within
Output	Type	Non-isolated Open Collector Output (Negative logic *1)
	Number of Channels	32ch (1common)
	Output rated voltage	30VDC (Max.)
	Output rated current	40mA(per channel) (Max.)
	Response time	200nsec within (Variable with pull-up resistance)
Common	External supply capable current	5VDC 350mA(Max)
	Connecting distance	1.5m(Typ.)(depending on wiring environment)
	I/O address	Any 32-byte boundary
	Interruption level	1 level use
	Boards in one system	Maximum of 16 boards can be install in a same system.
	Power consumption	3.3VDC 350mA (Max.)
	Bus specification	PCI Express Base Specification Rev. 1.0a x1
	Dimension (mm)	121.69(L)×110.18(H)
	Weight	100g

*1 Data "0" and "1" correspond to the High and Low levels, respectively.

Installation Environment Requirements

Item	Specifications
Operating ambient temperature	0 - 50°C
Operating ambient humidity	10 - 90%RH (No condensation)
Floating dust particles	Not to be excessive
Corrosive gases	None
Standard	VCCI Class A, CE Marking (EMC Directive Class A, RoHS Directive)

Support Software

Name	Contents	How to get
Windows Version Digital I/O Driver software API-DIO(WDM)	The Windows device driver is provided as a form of Windows API functions. Various sample programs such as C# and Visual Basic, .NET, Visual C++, Python etc. and diagnostic program useful for checking operation is provided.	Download from the CONTEC website *1
Linux Version Digital I/O Driver software API-DIO(LNX)	The Linux device driver is provided as a shared library. The software includes various sample programs such as gcc (C, C++) and Python programs as well as a configuration tool to configure the device settings.	Download from the CONTEC website *1
Software Development Tool Kits (SDK) and Support Software	In addition to the device drivers, we offer many software programs for using CONTEC devices in an easier manner.	Download from the CONTEC website *2

*1 Download the files from the following URL.

<https://www.contec.com/download/>

*2 For supported software, search the CONTEC website for this product and view the product page <https://www.contec.com/>

Optional Products

Product Name	Model type	Description
Shielded Cable with Two 96-Pin Half-Pitch Connectors	PCB96PS-0.5P	0.5m
	PCB96PS-1.5P	1.5m
Flat Cable with 96-pin Half-Pitch Connectors at Both Ends	PCB96P-1.5	1.5m
Shielded Cable with One 96-pin Half-Pitch Connector	PCA96PS-0.5P	0.5m
	PCA96PS-1.5P	1.5m
Flat Cable with One 96-pin Half-Pitch Connector	PCA96P-1.5	1.5m
Connection Conversion Shield Cable (96P→37P x 2)	PCB96WS-1.5P	1.5m
Screw Terminal (M3 * 96)	EPD-96A	*1 *2
Terminal Unit for Relay Terminal Banks	EPD-96	*2
Screw Terminal (M3 * 37P)	EPD-37A	*1 *3
Screw Terminal (M3.5 * 37)	EPD-37	*3
Screw Terminal	DTP-64A	*2
General Purpose Terminal	DTP-3C	*3
Screw Terminal	DTP-4C	*3
Signal monitor Accessory for Digital I/O (64bits)	CM-64L	*2
Signal monitor Accessory for Digital I/O (32bits)	CM-32L	*3
Connector Conversion Board (96pin→37pinx2)	CCB-96	*4

*1 "Spring-up" type terminal is used to prevent terminal screws from falling off

*2 PCB96P or PCB96PS optional cable is required separately.

*3 PCB96WS optional cable is required separately.

*4 Option cable PCB96P or PCB96PS, and the cable for 37-pin D-SUB are required separately.

Connecting an Interface Connector

Connecting an Interface Connector

To connect an external device to this product, plug the cable from the device into the interface connector (CN1) shown below.

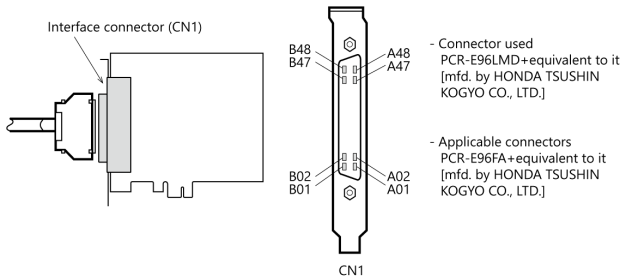

Layout on the Interface Connector(CN1)

+5V	Vcc	B48	[49] B48	[1] A48	A48	Vcc	+5V				
	Vcc	B47			A47	Vcc					
+7 port (Output)	O-77	B46	[48] B46	[2] A47	A46	I-37	+3 port (Input)				
	O-76	B45			A45	I-36					
	O-75	B44			A44	I-35					
	O-74	B43			A43	I-34					
	O-73	B42			A42	I-33					
	O-72	B41			A41	I-32					
	O-71	B40			A40	I-31					
+6 port (Output)	O-70	B39	[47] B39	[3] A40	A39	I-30	+2 port (Input)				
	O-67	B38			A38	I-27					
	O-66	B37			A37	I-26					
	O-65	B36			A36	I-25					
	O-64	B35			A35	I-24					
	O-63	B34			A34	I-23					
	O-62	B33			A33	I-22					
Signal common	GND	B30	[46] B30	[4] A33	A32	I-21	Signal common				
	GND	B29			A31	I-20					
	N.C.	N.C.			B28	[45] B28		[5] A30	A30	GND	N.C.
		N.C.			B27				A29	GND	
		N.C.			B26				A28	N.C.	
		N.C.			B25				A27	N.C.	
		N.C.			B24				A26	N.C.	
N.C.		B23	A25	N.C.							
N.C.		B22	A24	N.C.							
+5V	Vcc	B20	[44] B20	[6] A24	A23	N.C.	+5V				
	Vcc	B19			A22	N.C.					
	+5 port (Output)	O-57			B18	[43] B18		[7] A23	A21	N.C.	+1 port (Input)
		O-56			B17				A20	Vcc	
		O-55			B16				A19	Vcc	
		O-54			B15				A18	I-17	
		O-53			B14				A17	I-16	
O-52		B13	A16	I-15							
O-51		B12	A15	I-14							
+4 port (Output)	O-47	B10	[42] B10	[8] A23	A14	I-13	+0 port (Input)				
	O-46	B09			A13	I-12					
	O-45	B08			A12	I-11					
	O-44	B07			A11	I-10					
	O-43	B06			A10	I-07					
	O-42	B05			A09	I-06					
	O-41	B04			A08	I-05					
Signal common	GND	B02	[41] B02	[9] A23	A07	I-04	Signal common				
	GND	B01			A06	I-03					

[] shows the pin numbers specified by HONDATSUSHIN KOGYO CO., LTD.

Signal name	Description
I-00 - I-37	32 input signal pins. Connect output signals from the external device to these pins.
O-40 - O-77	32 output signal pins. Connect these pins to the input signal pins of the external device.
Vcc	Output +5V. The current that can be supplied is 350mA(Max).
GND	This pin is connected to the slot's GND.
N.C.	This pin is left unconnected.

Connecting Input and Output Signals

Input Circuit

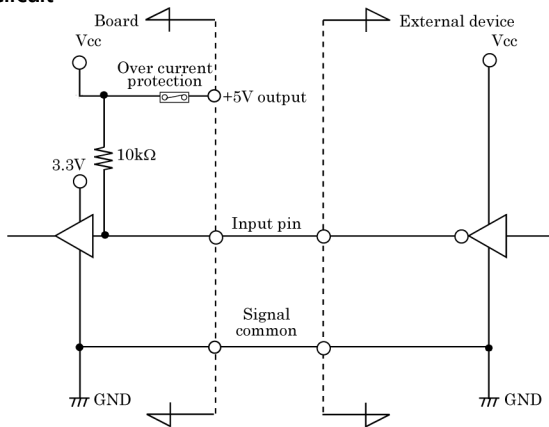

* I-xx represents an input pin.

One overcurrent protection components is connected for Vcc(+5V) terminal.

External digital signals given to signal inputs are TTL levels. The individual input signals are passed to the personal computer as negative logic signals. As each of the signal inputs is pulled up internally, the output of a relay contact or semiconductor switch can be connected directly between the signal input and the signal common pin.

Connecting a Switch (An Example to use Input I-00)

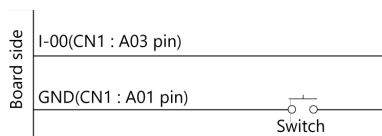

When the switch is ON, the corresponding bit contains 1.
When the switch is OFF, by contrast, the bit contains 0.

Output Circuit

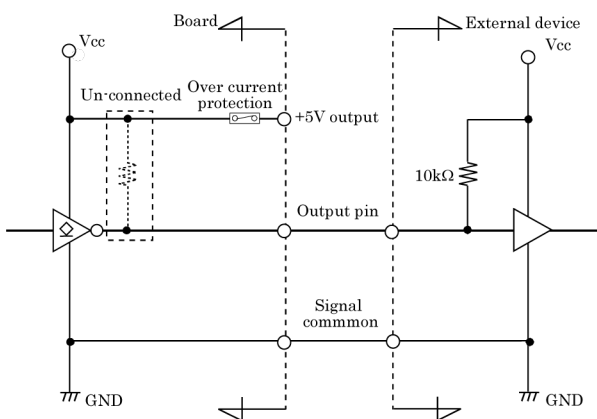

* O-xx represents an output pin.

One overcurrent protection components is connected for Vcc(+5V) terminal.

Signal outputs are open-collector outputs; individual output signals are sent to the external device as negative logic signals. Note that each signal output must be pulled up at the external device as it is not pulled up internally.

CAUTION

When the PC is turned on, all output are reset to OFF.

Connection to the LED (An Example to use Output O-40)

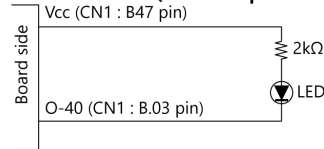

When "1" is output to a relevant bit, the corresponding LED comes on.
When "0" is output to the bit, in contrast, the LED goes out.

Surge Protection

When connecting to digital outputs a load that may generate a voltage surge or current, for example an inductive load such as a relay coil or incandescent lamp, suitable protection measures are required to prevent damage to the output stage or malfunction owing to noise. The instantaneous interruption of current flowing through a coil, including a relay, results in the sudden generation of a high-voltage pulse. If the voltage exceeds the withstand voltage of the transistor, the transistor performance may be degraded or the transistor may be damaged. To prevent this, be sure to connect a surge absorption element when driving an inductive load including a relay coil. Examples of measures against voltage surge are shown in Figure below.

-Examples of use of relay coil

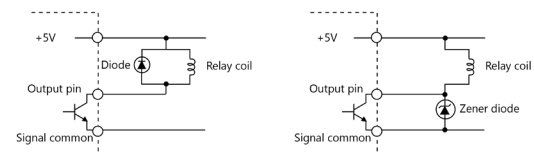

External power voltage < Zener diode voltage

-Examples of use of lump

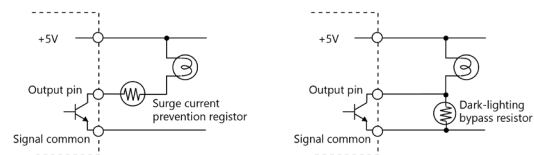

CAUTION

The protection circuit must be installed less than 50 cm from the load and contact to provide effective protection.

A Protection Function of the +5V Outputs

A protection function, which prevents excessive current flow from the +5V outputs, is attached to this board. In case of accidental short of the +5V output and GND, for example, the function works.

Block Diagram

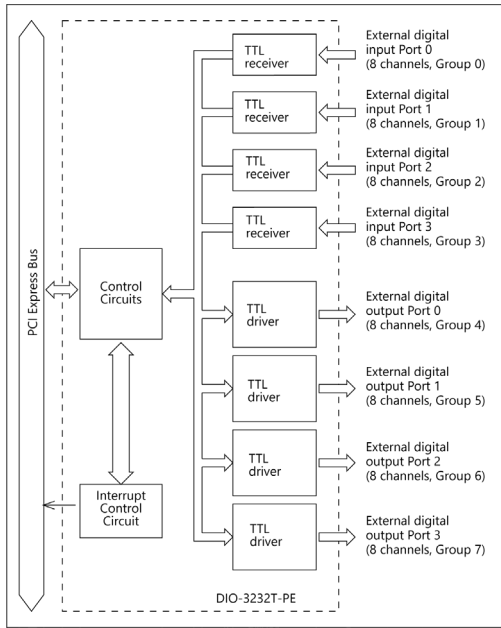

Nomenclature of Product Components

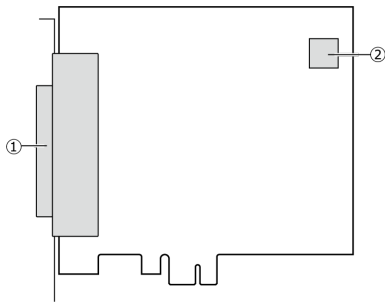

No.	Name
1	Interface Connector
2	Board ID Setting Switch