

Digital I/O Board for PCI
DIO-6464T2-PCI



* Specifications, color and design of the products are subject to change without notice.

Features

Non-isolated TTL level input, non-isolated open-collector output
This product has the 64ch of non-isolated TTL level input and 64ch of non-isolated open-collector output whose response time is 200nsec. Output rating : max 30VDC, 40mA per pin.

You can use 16 input signals as interrupt request signals
You can use 16 input signals as interrupt request signals and also disable or enable the interrupt in bit units and select the edge of the input signals, at which to generate an interrupt.

This product has a digital filter to prevent wrong recognition of input signals from carrying noise or a chattering
This product has a digital filter to prevent wrong recognition of input signals from carrying noise or a chattering. All input terminals can be added a digital filter, and the setting can be performed by software.

Windows/Linux support device driver
Using the device driver API-TOOL makes it possible to create applications of Windows/Linux. In addition, a diagnostic program by which the operations of hardware can be checked is provided.

Packing List

Product...1
Please read the following...1

Physical Dimensions

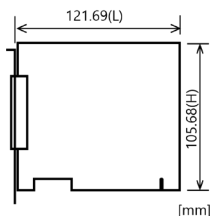

The standard outside dimension (L) is the distance from the end of the board to the outer surface of the slot cover.

This product is a PCI bus-compliant interface board for input/output of digital signals.

This product features 64 non-isolated TTL level inputs and 64 non-isolated open-collector outputs. You can use 16 of its input signals as interrupt request signals. In addition, the digital filter function to prevent wrong recognition of input signals is provided.

Windows/Linux device driver is supported with this product.

- * The contents in this document are subject to change without notice.
- * Visit the CONTEC website to check the latest details in the document.
- * The information in the data sheets is as of October, 2025.

Specifications

Function specification

Item		Specifications
Input	Type	Non-isolated TTL-Level Input (Negative logic *1)
	Number of Channels	64ch (16 channels for interrupts) (1 common)
	Input resistance	Pull up 10kΩ (1TTL load)
	Interrupts	Combine 16 interrupt signals to one interrupt request signal as the INTA. Either rising edge or falling edge of input signal can generate interrupt.
	Response time	200nsec within
Output	Type	Open Collector Output (Negative logic *1)
	Number of Channels	64ch (1 common)
	Output rated voltage	30VDC (Max)
	Output rated current	40mA/channel (Max)
	Response time	200nsec within
Common	External supply capable current	5VDC 1A (Max) *3
	Connecting distance	1.5m(Typ.) (depending on wiring environment)
	I/O address	Any 32-byte boundary
	Interruption level	1 level use
	Boards in one system	Maximum of 16 boards can be install in a same system.
	Power consumption	5VDC 450mA (Max) *4
	PCI bus specification	32bit, 33MHz, Universal key shapes supported *2
	Dimension (mm)	121.69(L) x 105.68(H)
Weight	100g	

- *1 Data "0" and "1" correspond to the High and Low levels, respectively.
- *2 This product requires power supply at +5V from an expansion slot (it does not work on a machine with a +3.3V power supply alone).
- *3 Because it supplies the +5V power supply from an expansion slot, the external supply capable current depends on the PC.
- *4 The power consumption does not include it in the external supply capable current.

Installation Environment Requirements

Item	Specifications
Operating ambient temperature	0 - 50°C
Operating ambient humidity	10 - 90%RH (No condensation)
Floating dust particles	Not to be excessive
Corrosive gases	None
Standard	VCCI Class A, CE Marking (EMC Directive Class A, RoHS Directive), UKCA

Support Software

Name	Contents	How to get
Windows Version Digital I/O Driver software API-DIO(WDM)	The Windows device driver is provided as a form of Windows API functions. Various sample programs such as C# and Visual Basic, .NET, Visual C++, Python etc. and diagnostic program useful for checking operation is provided.	Download from the CONTEC website *1
Linux Version Digital I/O Driver software API-DIO(LNX)	The Linux device driver is provided as a shared library. The software includes various sample programs such as gcc (C, C++) and Python programs, as well as a configuration tool to configure the device settings.	Download from the CONTEC website *1
Software Development Tool Kits (SDK) and Support Software	In addition to the device drivers, we offer many software programs for using CONTEC devices in an easier manner.	Download from the CONTEC website *2

- *1 Download the files from the following URL
<https://www.contec.com/download/>
- *2 For supported software, search the CONTEC website for this product and view the product page.
<https://www.contec.com/>

Optional Products

Product Name	Model type	Description
Shielded Cable With Two 100pin Connector	PCB100PS-0.5	0.5m
	PCB100PS-1.5	1.5m
Connection Conversion Shield Cable (100P-96P)	PCB100/96PS-1.5	1.5m
Flat Cable with One 100-Pin Connector	PCA100P-1.5	1.5m
Connection Conversion Shield Cable (100pin-37pin D-SUB x2)	PCB100WS-1.5	1.5m
Screw Terminal (M3 * 100)	EPD-100A	*1 *2 *5
Screw Terminal (M3 * 96)	EPD-96A	*1 *3 *5
Terminal Unit for Relay Terminal Banks	EPD-96	*3 *5
Screw Terminal (M3 * 37P)	EPD-37A	*1 *4 *6
Screw Terminal (M3.5 * 37)	EPD-37	*4 *6
Screw Terminal	DTP-64A	*3 *5
General Purpose Terminal	DTP-3C	*4 *6
Screw Terminal	DTP-4C	*4 *6
Signal monitor Accessory for Digital I/O (64bits)	CM-64L	*3 *5
Connector Conversion Board (96pin-37pinx2)	CCB-96	*3 *5

- *1 "Spring-up" type terminal is used to prevent terminal screws from falling off.
- *2 PCB100PS optional cable is required separately.
- *3 PCB100/96PS optional cable is required separately.
- *4 PCB100WS optional cable is required separately.
- *5 If using both the CNA and CNB connectors, two each of the terminal block and cable sets are required.
- *6 If using both the CNA and CNB connectors, two cable sets are required.
 You will also require sufficient terminal blocks for the number of I/O points you are using.

Connecting an Interface Connector

Connecting an Interface Connector

To connect an external device to this product, plug the cable from the device into the interface connector (CNA, CNB) shown below.

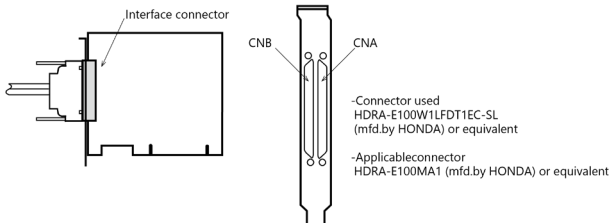

Layout on the Interface Connector(CNA, CNB)

CNB					CNA				
+5V	Vcc 100	50	Vcc	+5V	Signal Common	GND 1	51	GND	Signal Common
	Vcc 99	49	Vcc			GND 2	52	GND	
	O-F7 98	48	O-B7			GND 3	53	GND	
	O-F6 97	47	O-B6			GND 4	54	GND	
	O-F5 96	46	O-B5			GND 5	55	GND	
	O-F4 95	45	O-B4			GND 6	56	GND	
	O-F3 94	44	O-B3			I-00 7	57	I-40	
	O-F2 93	43	O-B2			I-01 8	58	I-41	
	O-F1 92	42	O-B1			I-02 9	59	I-42	
	O-F0 91	41	O-B0			I-03 10	60	I-43	
	O-E7 90	40	O-A7			I-04 11	61	I-44	
	O-E6 89	39	O-A6			I-05 12	62	I-45	
	O-E5 88	38	O-A5			I-06 13	63	I-46	
	O-E4 87	37	O-A4			I-07 14	64	I-47	
	O-E3 86	36	O-A3			I-10 15	65	I-50	
	O-E2 85	35	O-A2			I-11 16	66	I-51	
	O-E1 84	34	O-A1			I-12 17	67	I-52	
	O-E0 83	33	O-A0			I-13 18	68	I-53	
	GND 82	32	GND			I-14 19	69	I-54	
	GND 81	31	GND			I-15 20	70	I-55	
	GND 80	30	GND			I-16 21	71	I-56	
	GND 79	29	GND			I-17 22	72	I-57	
	GND 78	28	GND			Vcc 23	73	Vcc	
	GND 77	27	GND			Vcc 24	74	Vcc	
	N.C. 76	26	N.C.			N.C. 25	75	N.C.	
	N.C. 75	25	N.C.			N.C. 26	76	N.C.	
	Vcc 74	24	Vcc			N.C. 27	77	GND	
	Vcc 73	23	Vcc			GND 28	78	GND	
	O-D7 72	22	O-97			GND 29	79	GND	
	O-D6 71	21	O-96			GND 30	80	GND	
	O-D5 70	20	O-95			GND 31	81	GND	
	O-D4 69	19	O-94			GND 32	82	GND	
	O-D3 68	18	O-93			I-20 33	83	I-60	
	O-D2 67	17	O-92			I-21 34	84	I-61	
	O-D1 66	16	O-91			I-22 35	85	I-62	
	O-D0 65	15	O-90			I-23 36	86	I-63	
	O-C7 64	14	O-87			I-24 37	87	I-64	
	O-C6 63	13	O-86			I-25 38	88	I-65	
	O-C5 62	12	O-85			I-26 39	89	I-66	
	O-C4 61	11	O-84			I-27 40	90	I-67	
	O-C3 60	10	O-83			I-30 41	91	I-70	
	O-C2 59	9	O-82			I-31 42	92	I-71	
	O-C1 58	8	O-81			I-32 43	93	I-72	
	O-C0 57	7	O-80			I-33 44	94	I-73	
	GND 56	6	GND			I-34 45	95	I-74	
	O-D0 55	5	GND			I-35 46	96	I-75	
	GND 54	4	GND			I-36 47	97	I-76	
	GND 53	3	GND			I-37 48	98	I-77	
	GND 52	2	GND			Vcc 49	99	Vcc	
	GND 51	1	GND			Vcc 50	100	Vcc	

* I-00 - I-17 can be used as interrupt signal.

Signal name	Description
I-00 - I-77	64 input signal pins. Connect output signals from the external device to these pins.
O-80 - O-F7	64 output signal pins. Connect these pins to the input signal pins of the external device.
Vcc	Output +5V. The current that can be supplied is 1A(Max). The permitted current per pin of connector is 0.3A. Connect the number of pins required to supply the total current.
GND	Connect the positive side of the external power supply. These pins are common to 16 output signal pins.
N.C.	This pin is left unconnected.

Pin assignments for connecting to the PCB100/96PS

PCB100/96PS

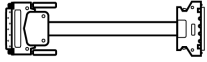

When connected to CNB of the product				When connected to CNA of the product			
Signal Common	GND B01 GND B02	A01 GND A02 GND	Signal Common	Signal Common	GND B01 GND B02	A01 GND A02 GND	Signal Common
+C port (Output)	O-C0 B03	A03 O-80	+8 port (Output)	+4 port (Input)	I-40 B03	A03 I-00	+0 port (Input)
	O-C1 B04	A04 O-81			I-41 B04	A04 I-01	
	O-C2 B05	A05 O-82			I-42 B05	A05 I-02	
	O-C3 B06	A06 O-83			I-43 B06	A06 I-03	
	O-C4 B07	A07 O-84			I-44 B07	A07 I-04	
	O-C5 B08	A08 O-85			I-45 B08	A08 I-05	
	O-C6 B09	A09 O-86			I-46 B09	A09 I-06	
O-C7 B10	A10 O-87	I-47 B10	A10 I-07				
+D port (Output)	O-D0 B11	A11 O-90	+9 port (Output)	+5 port (Input)	I-50 B11	A11 I-10	+1 port (Input)
	O-D1 B12	A12 O-91			I-51 B12	A12 I-11	
	O-D2 B13	A13 O-92			I-52 B13	A13 I-12	
	O-D3 B14	A14 O-93			I-53 B14	A14 I-13	
	O-D4 B15	A15 O-94			I-54 B15	A15 I-14	
	O-D5 B16	A16 O-95			I-55 B16	A16 I-15	
	O-D6 B17	A17 O-96			I-56 B17	A17 I-16	
O-D7 B18	A18 O-97	I-57 B18	A18 I-17				
+5V	Vcc B19	A19 Vcc	+5V	+5V	Vcc B19	A19 Vcc	+5V
	Vcc B20	A20 Vcc			Vcc B20	A20 Vcc	
Unconnected	NC B21	A21 N.C.	Unconnected	Unconnected	NC B21	A21 N.C.	Unconnected
	NC B22	A22 N.C.			NC B22	A22 N.C.	
	NC B23	A23 N.C.			NC B23	A23 N.C.	
	NC B24	A24 N.C.			NC B24	A24 N.C.	
	NC B25	A25 N.C.			NC B25	A25 N.C.	
	NC B26	A26 N.C.			NC B26	A26 N.C.	
	NC B27	A27 N.C.			NC B27	A27 N.C.	
	NC B28	A28 N.C.			NC B28	A28 N.C.	
Signal Common	GND B29	A29 GND	Signal Common	Signal Common	GND B29	A29 GND	Signal Common
	GND B30	A30 GND			GND B30	A30 GND	
+E port (Output)	O-E0 B31	A31 O-A0	+A port (Output)	+6 port (Input)	I-60 B31	A31 I-20	+2 port (Input)
	O-E1 B32	A32 O-A1			I-61 B32	A32 I-21	
	O-E2 B33	A33 O-A2			I-62 B33	A33 I-22	
	O-E3 B34	A34 O-A3			I-63 B34	A34 I-23	
	O-E4 B35	A35 O-A4			I-64 B35	A35 I-24	
	O-E5 B36	A36 O-A5			I-65 B36	A36 I-25	
	O-E6 B37	A37 O-A6			I-66 B37	A37 I-26	
O-E7 B38	A38 O-A7	I-67 B38	A38 I-27				
+F port (Output)	O-F0 B39	A39 O-B0	+B port (Output)	+7 port (Input)	I-70 B39	A39 I-30	+3 port (Input)
	O-F1 B40	A40 O-B1			I-71 B40	A40 I-31	
	O-F2 B41	A41 O-B2			I-72 B41	A41 I-32	
	O-F3 B42	A42 O-B3			I-73 B42	A42 I-33	
	O-F4 B43	A43 O-B4			I-74 B43	A43 I-34	
	O-F5 B44	A44 O-B5			I-75 B44	A44 I-35	
	O-F6 B45	A45 O-B6			I-76 B45	A45 I-36	
O-F7 B46	A46 O-B7	I-77 B46	A46 I-37				
+5V	Vcc B47	A47 Vcc	+5V	+5V	Vcc B47	A47 Vcc	+5V
	Vcc B48	A48 Vcc			Vcc B48	A48 Vcc	

* [] shows pin numbers specified by HONDA TSUSHIN KOGYO CO., LTD

Pin assignments for connecting to the PCB100WS

PCB100WS



CNA of PCB100WS connected to CNB of product

	NC	19			
+5V	Vcc	18	37	Vcc	+5V
+9 port (Output)	O-97	17	36	O-B7	+8 port (Output)
	O-96	16	35	O-B6	
	O-95	15	34	O-B5	
	O-94	14	33	O-B4	
	O-93	13	32	O-B3	
	O-92	12	31	O-B2	
	O-91	11	30	O-B1	
O-90	10	29	O-B0	+A port (Output)	
O-87	9	28	O-A7		
O-86	8	27	O-A6		
O-85	7	26	O-A5		
O-84	6	25	O-A4		
O-83	5	24	O-A3		
O-82	4	23	O-A2		
O-81	3	22	O-A1		
O-80	2	21	O-A0	Signal Common	
Signal Common	GND	1	20		GND

CNA of PCB100WS connected to CNA of product

	NC	19			
+5V	Vcc	18	37	Vcc	+5V
+1 port (Input)	I-17	17	36	I-37	+3 port (Input)
	I-16	16	35	I-36	
	I-15	15	34	I-35	
	I-14	14	33	I-34	
	I-13	13	32	I-33	
	I-12	12	31	I-32	
	I-11	11	30	I-31	
I-10	10	29	I-30		
I-07	9	28	I-27		
I-06	8	27	I-26		
I-05	7	26	I-25		
I-04	6	25	I-24		
I-03	5	24	I-23		
I-02	4	23	I-22		
I-01	3	22	I-21	Signal Common	
I-00	2	21	I-20		
Signal Common	GND	1	20	GND	

CNB of PCB100WS connected to CNB of product

	NC	19			
+5V	Vcc	18	37	Vcc	+5V
+D port (Output)	O-D7	17	36	O-F7	+F port (Output)
	O-D6	16	35	O-F6	
	O-D5	15	34	O-F5	
	O-D4	14	33	O-F4	
	O-D3	13	32	O-F3	
	O-D2	12	31	O-F2	
	O-D1	11	30	O-F1	
O-D0	10	29	O-F0		
O-C7	9	28	O-E7		
O-C6	8	27	O-E6		
O-C5	7	26	O-E5		
O-C4	6	25	O-E4		
O-C3	5	24	O-E3		
O-C2	4	23	O-E2		
O-C1	3	22	O-E1	Signal Common	
O-C0	2	21	O-E0		
Signal Common	GND	1	20	GND	

CNB of PCB100WS connected to CNA of product

	NC	19			
+5V	Vcc	18	37	Vcc	+5V
+5 port (Input)	I-57	17	36	I-77	+7 port (Input)
	I-56	16	35	I-76	
	I-55	15	34	I-75	
	I-54	14	33	I-74	
	I-53	13	32	I-73	
	I-52	12	31	I-72	
	I-51	11	30	I-71	
I-50	10	29	I-70		
I-47	9	28	I-67		
I-46	8	27	I-66		
I-45	7	26	I-65		
I-44	6	25	I-64		
I-43	5	24	I-63		
I-42	4	23	I-62		
I-41	3	22	I-61	Signal Common	
I-40	2	21	I-60		
Signal Common	GND	1	20	GND	

Connecting Input and Output Signals

Input Circuit

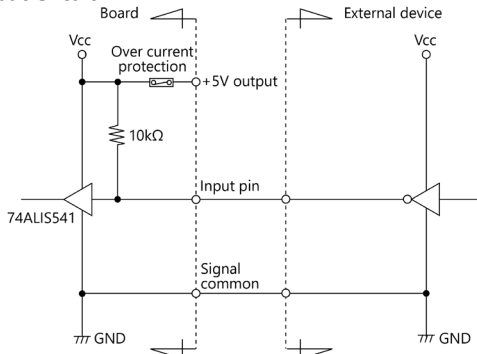

* I-xx represents an input pin.

One over current protection is connected for Vcc(+5V) terminal.

The input circuits of interface blocks of the product is illustrated in the figure above.

External digital signals given to signal inputs are TTL levels. The individual input signals are passed to the personal computer as negative logic signals. As each of the signal inputs is pulled up internally, the output of a relay contact or semiconductor switch can be connected directly between the signal input and the signal common pin.

Connecting a Switch (An Example to use Input I00)

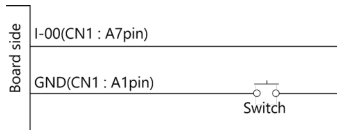

When the switch is ON, the corresponding bit contains 1.
When the switch is OFF, by contrast, the bit contains 0.

Output Circuit

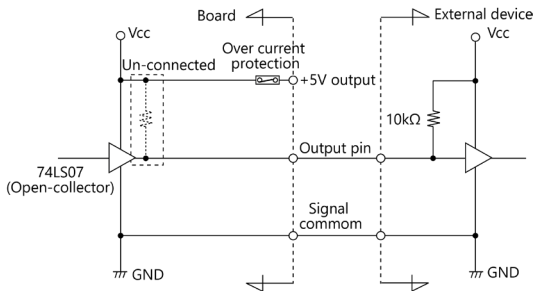

* O-xx represent an output pin.

One over current protection is connected for Vcc(+5V) terminal.

The output circuits of interface blocks of the product is illustrated in the figure above.

Signal outputs are open-collector outputs; individual output signals are sent to the external device as negative logic signals. Note that each signal output must be pulled up at the external device as it is not pulled up internally.

CAUTION

When the PC is turned on, all outputs are reset to OFF.

Connection to the LED (An Example to use Output O-80)

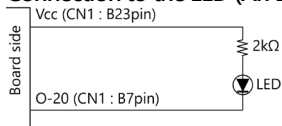

When "1" is output to a relevant bit, the corresponding LED comes on.
When "0" is output to the bit, in contrast, the LED goes out.

Surge Protection

When connecting to digital outputs a load that may generate a voltage surge or current, for example an inductive load such as a relay coil or incandescent lamp, suitable protection measures are required to prevent damage to the output stage or malfunction owing to noise. The instantaneous interruption of current flowing through a coil, including a relay, results in the sudden generation of a high-voltage pulse. If the voltage exceeds the withstand voltage of the transistor, the transistor performance may be degraded or the transistor may be damaged. To prevent this, be sure to connect a surge absorption element when driving an inductive load including a relay coil. Examples of measures against voltage surge are shown in Figure below.

-Examples of use of relay coil

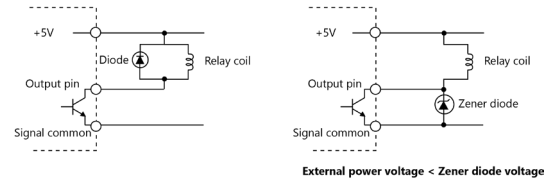

-Examples of use of lump

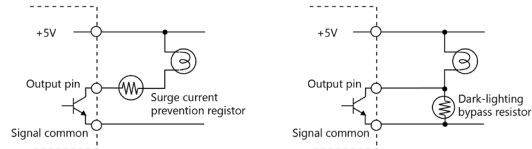

CAUTION

The protection circuit must be installed less than 50 cm from the load and contact to provide effective protection.

Protection Function of the +5V Outputs

An overcurrent protection circuit is attached to this board.

Block Diagram

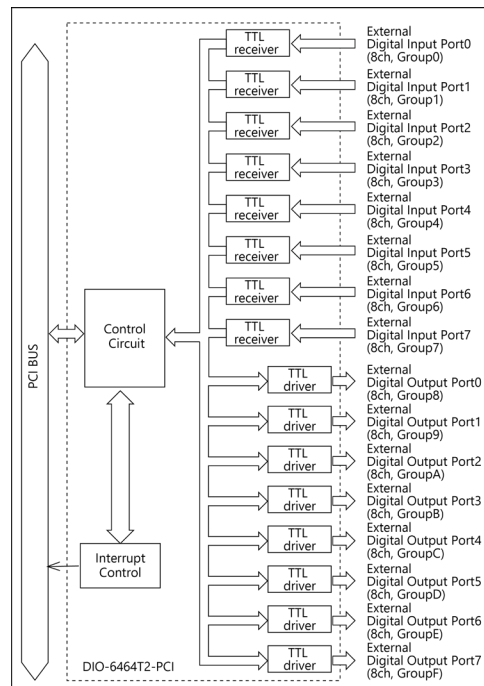

Nomenclature of Product Components

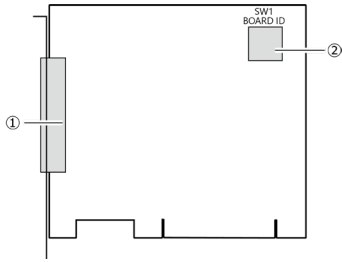

No.	Name
1	Interface Connector
2	Board ID Setting Switch