

IEEE802.11ax/ac/n/a/b/g Embedded Wireless LAN
(Access point / Station)

FXE5000 Series

FXE5000-US FXE5000-EU FXE5000-KR



* Specifications, color and design of the products are subject to change without notice.

Features

Wi-Fi 6E (IEEE 802.11ax) compliant high-speed and low-latency communication

(2.4GHz and 5GHz / 6GHz bands can be used simultaneously)

Effective throughput is greatly improved, and data transmission and reception is 2.8 times faster (2.4Gbps) than Wi-Fi 5 (800Mbps). New technologies such as OFDMA(Orthogonal Frequency Division Multiple Access) and MU-MIMO (Multi-User MIMO) have been implemented, greatly improving throughput degradation and delays that occur when many satellite stations are used simultaneously. In addition to the conventional 2.4 GHz and 5 GHz bands, the new 6 GHz band * 1 can be used to reduce radio interference and create a faster and more stable communication environment.

In addition, the 2.4 GHz band and the 5 GHz/6 GHz band can be used simultaneously.

*1 Single station or dual station operation only

Mesh Wi-Fi network

The wireless mesh network function allows a single network group (ESSID) to be configured by multiple access points in a mesh pattern. Even if a failure occurs in any part of the communication path, the network can be built resistant to failures, such as automatically securing the best alternative path and maintaining communication connections. Wireless connections between access points make it easy to expand the communication area by simply increasing the number of access points.

Smart Roaming (Duplex)

Dual Station Mode is installed to extend communication from one wireless connection to two wireless connections. If one wireless connection is lost, data communication will not be lost while roaming because another wireless connection is available. Contec's unique tuning for "uninterruptible wireless LAN" enables high-dimensional roaming.

Supports a various power supply

AC adaptor (sold separately) and 5~30VDC DC power supply are supported.

This product can be switched between access point, station (client), and repeater operation modes

By switching the operation mode, you can use this product as not only an access point but also as a station (client) and a repeater. You can use this product as a wireless LAN converter for a wired LAN device.

You can also use both 5 GHz / 6GHz and 2.4 GHz interfaces simultaneously in Dual Station Mode.

The proprietary encryption technology "WSL" that is available along with WPA3/WPA2/WPA and WEP.

In addition to the certifications for advanced security standards WPA3/WPA2/WPA and IEEE802.1X, this product is also equipped with our proprietary encryption technology "WSL", which can be used at the same time as these certifications. MAC address filtering and ESSID hiding

This product is a built-in type wireless LAN board that is compatible with Wi-Fi 6E (IEEE 802.11ax) and wide input power supply (5 - 30 VDC).

It has various functions such as smart roaming (duplex) and mesh Wi-Fi network support. By simply connecting a LAN cable to the LAN port (RJ-45 connector) of a LAN device, you can turn the device into a wireless LAN device with advanced security, stable communication, and excellent maintainability using the latest standards, regardless of the OS or CPU.

By switching modes, it can be used not only as an access point (master station) but also as a station (slave station) or repeater. It can be used as an access point or repeater.

In Dual Station Mode, you can use both 5 GHz/6 GHz and 2.4 GHz interfaces simultaneously.

- * The contents in this document are subject to change without notice.
- * Visit the CONTEC website to check the latest details in the document.
- * The information in the data sheets is as of March, 2026.

are also supported.

Features variety of functions, including VLAN and a virtual AP function

This product is equipped with a VLAN function for constructing virtual networks and a virtual AP function for operating one AP as multiple virtual APs with different security settings. Also, large capacity event logs can be saved.

Specifications

Function specification

Item	FXE5000-US, FXE5000-KR, FXE5000-EU
Unit Type	Single Station/Access point/Repeater/ Dual Station/Mesh
Wired LAN	
Ethernet standard	IEEE802.3 (10BASE-T), IEEE802.3u (100BASE-TX), IEEE802.3ab (1000BASE-T)
Port Speed/Type/Port Number	10/100/1000Mbps / Half Duplex, Full Duplex / 1
Wireless LAN	
Security	
IEEE802.11ax/ac/n	WPA(AES), WPA2(AES), WPA3, WPA3 192bit, WPA-PSK(AES), WPA2-PSK(AES), WPA3-SAE, WSL(combination mentioned above are possible)
IEEE802.11a/b/g	WEP(Open/Shared Key) *1, WPA(AES, TKIP), WPA-PSK(AES,TKIP), WPA2(AES, TKIP), WPA2-PSK(AES,TKIP), WPA3, WPA3 192bit, WPA3-SAE, IEEE802.1X(EAP-TLS, PEAP), WSL(combination mentioned above are possible)
Antenna	Dipole Antenna x2 MIMO
External Dimensions (mm)	60.0(W) x 89.2(D) x 17.9(H)
Weight	100g

*1 WEP encryption for access points only.

FXE5000-US 5GHz/6GHz, 2.4GHz interface specifications

Item	FXE5000-US
5GHz/6GHz	
Wireless Standard	IEEE802.11ax, IEEE802.11ac, IEEE802.11n, IEEE802.11a
Band Width	20/40/80/160MHz
The Number of Connectable Devices	512
Channel	5GHz : 25ch (36, 40, 44, 48ch, 52, 56, 60, 64ch, 100, 104, 108, 112, 116, 120, 124, 128, 132, 136, 140, 144ch, 149, 153, 157, 161, 165ch) 6GHz : 24ch (1, 5, 9, 13, 17, 21, 25, 29, 33, 37, 41, 45, 49, 53, 57, 61, 65, 69, 73, 77, 81, 85, 89, 93ch)
Data transmission speed *1	IEEE802.11ax 2402 - 0.9Mbps [MCS0 - 11, 0.8us/1.6us/3.2us GI] IEEE802.11ac 866 - 7.2Mbps [MCS0 - 9, Short/Long GI] IEEE802.11n 300 - 6.5Mbps [MCS0 - 15, Short/Long GI] IEEE802.11a 54, 48, 36, 24, 18, 12, 9, 6Mbps
2.4GHz	
Wireless Standard	IEEE802.11ax, IEEE802.11n, IEEE802.11b, IEEE802.11g
Band Width	20/40MHz
The Number of Connectable Devices	128
Channel	11ch (1 - 11)
Data transmission speed *1	IEEE802.11ax 574 - 0.9Mbps [MCS0 - 11, 0.8us/1.6us/3.2us GI] IEEE802.11n 300 - 6.5Mbps [MCS0 - 15, Short/Long GI] IEEE802.11g 54, 48, 36, 24, 18, 12, 9, 6Mbps IEEE802.11b 11, 5.5, 2, 1Mbps

*1 WEP encryption for access points only.

FXE5000-KR 5GHz/6GHz, 2.4GHz interface specifications

Item	FXE5000-KR
5GHz/6GHz	
Wireless Standard	IEEE802.11ax, IEEE802.11ac, IEEE802.11n, IEEE802.11a
Band Width	20/40/80/160MHz
The Number of Connectable Devices	512
Channel	5GHz : 19ch(36, 40, 44, 48ch, 52, 56, 60, 64ch, 100, 104, 108, 112, 116, 120, 124ch, 149, 153, 157, 161ch) 6GHz : 59ch(1, 5, 9, 13, 17, 21, 25, 29, 33, 37, 41, 45, 49, 53, 57, 61, 65, 69, 73, 77, 81, 85, 89, 93, 97, 101, 105, 109, 113, 117, 121, 125, 129, 133, 137, 141, 145, 149, 153, 157, 161, 165, 169, 173, 177, 181, 185, 189, 193, 197, 201, 205, 209, 213, 217, 221, 225, 229ch)
Data transmission speed *1	IEEE802.11ax 2402 - 0.9Mbps [MCS0 - 11, 0.8us/1.6us/3.2us GI] IEEE802.11ac 866 - 7.2Mbps [MCS0 - 9, Short/Long GI] IEEE802.11n 300 - 6.5Mbps [MCS0 - 15, Short/Long GI] IEEE802.11a 54, 48, 36, 24, 18, 12, 9, 6Mbps
2.4GHz	
Wireless Standard	IEEE802.11ax, IEEE802.11n, IEEE802.11b, IEEE802.11g
Band Width	20/40MHz
The Number of Connectable Devices	128
Channel	13ch (1 - 13)
Data transmission speed *1	IEEE802.11ax 574 - 0.9Mbps [MCS0 - 11, 0.8us/1.6us/3.2us GI] IEEE802.11n 300 - 6.5Mbps [MCS0 - 15, Short/Long GI] IEEE802.11g 54, 48, 36, 24, 18, 12, 9, 6Mbps IEEE802.11b 11, 5.5, 2, 1Mbps

*1 WEP encryption for access points only.

FXE5000-EU 5GHz/6GHz, 2.4GHz interface specifications

Item	FXE5000-EU
5GHz/6GHz	
Wireless Standard	IEEE802.11ax, IEEE802.11ac, IEEE802.11n, IEEE802.11a
Band Width	20/40/80/160MHz
The Number of Connectable Devices	512
Channel	5GHz : 19ch(36, 40, 44, 48, 52, 56, 60, 64, 100, 104, 108, 112, 116, 120, 124, 128, 132, 136, 140) 6GHz : 24ch(1, 5, 9, 13, 17, 21, 25, 29, 33, 37, 41, 45, 49, 53, 57, 61, 65, 69, 73, 77, 81, 85, 89, 93)
Data transmission speed *1	IEEE802.11ax 2402 - 0.9Mbps [MCS0 - 11, 0.8us/1.6us/3.2us GI] IEEE802.11ac 866 - 7.2Mbps [MCS0 - 9, Short/Long GI] IEEE802.11n 300 - 6.5Mbps [MCS0 - 15, Short/Long GI] IEEE802.11a 54, 48, 36, 24, 18, 12, 9, 6Mbps
2.4GHz	
Wireless Standard	IEEE802.11ax, IEEE802.11n, IEEE802.11b, IEEE802.11g
Band Width	20/40MHz
The Number of Connectable Devices	128
Channel	13ch(1 - 13)
Data transmission speed *1	IEEE802.11ax 574 - 0.9Mbps [MCS0 - 11, 0.8us/1.6us/3.2us GI] IEEE802.11n 300 - 6.5Mbps [MCS0 - 15, Short/Long GI] IEEE802.11g 54, 48, 36, 24, 18, 12, 9, 6Mbps IEEE802.11b 11, 5.5, 2, 1Mbps

*1 WEP encryption for access points only.

Installation Environment Requirements

Item	FXE5000-US	FXE5000-KR	FXE5000-EU
Input voltage range	5VDC±5% (DC Jack), 5 - 30VDC±5% (Power Connector)		
Rating input current	1.87A(5V DC input), 0.78A(12V DC input), 0.39A(24V DC input), 0.32A(30V DC input)		
Operating ambient temperature	DC input	-20 - +40°C (without wind) -20 - +50°C (with air flow 0.6m/s)	
Operating ambient humidity	10 - 90%RH (No condensation)		
Floating dust particles	Not extreme		
Corrosive gases	None		
Line-noise resistance *1	Line noise	AC Power Line /±2kV (IEC61000-4-4 Level 3, EN61000-4-4 Level 3), Signal Line /±1kV (IEC61000-4-4 Level 3, EN61000-4-4 Level 3)	
	Static electricity resistance	Indirect Discharge /±8kV (IEC61000-4-2 Level 3, EN61000-4-2 Level 3)	
Vibration resistance	Sweep resistance	10 - 57Hz /semi-amplitude vibration 0.035mm, 57 - 150Hz/0.5G 40minutes each in X, Y, and Z directions (JIS C60068-2-6-compliant, IEC60068-2-6-compliant)	
Shock resistance	10G half-sine shock for 11ms in X, Y, and Z directions (JIS C 60068-2-27 -compliant, IEC 60068-2-27 -compliant)		
Standard	FCC Class A, IMDA, UL	KC	CE, UKCA

*1 Check with optional AC adapter FX-AC053.

Optional Products

Product Name	Type	Description
AC adapter *1	FX-AC053	AC adaptor (+5VDC 3A)

*1 Since FX-AC053 is a product for Japan, it may not be usable outside of Japan.

* Visit the CONTEC website for the latest optional products.

Included Items

Main Unit ...1
Please read the following ... 1
Simplified EU Declaration of Conformity ... 1 (FXE5000-EU only)
Setup Guide ... 1

Physical Dimensions

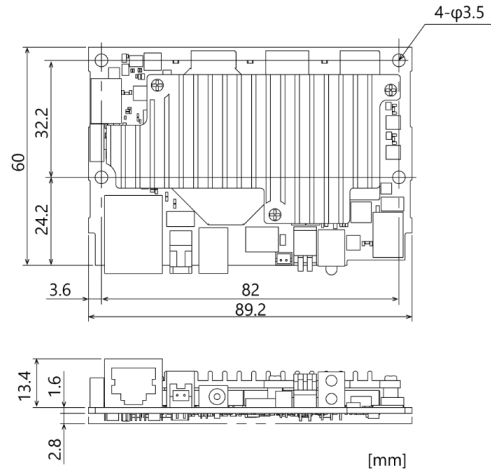

Component Name

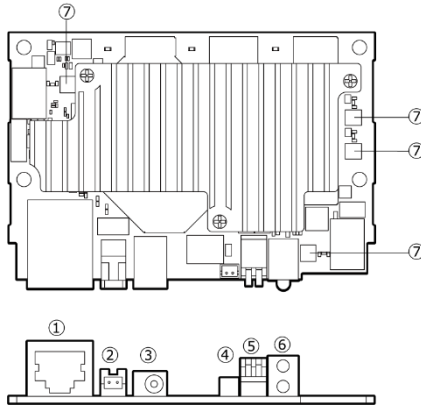

Functions of components

No.	Name	Function
1	LAN port	Connect the LAN cable to the PC.
2	Power connector * 1	Connect to the power connector when supplying power from an external source.
3	DC jack * 1	This jack is used for DC power.
4	INIT connector	This connector is used to initialize the printer.
5	DIP switch	This switch is used to initialize the machine.
6	LED display	This LED displays the status of the unit. The LED lights when the optional AC adaptor is connected.
7	Antenna connector	This is an antenna connector. J2 is antenna 1, and J4 is antenna 2.

*1 Use either the power connector or the DC jack for power supply.

Differences from FXE3000-US

The FXE5000-US has the following main differences from the previous FXE3000-US :

Title	FXE5000-US	FXE3000-US
Unit Type	Single Station/Access point/Repeater/ Dual Station/Mesh	Station/Access point/Repeater
Wired LAN		
Ethernet standard	IEEE802.3 (10BASE-T), IEEE802.3u (100BASE-TX), IEEE802.3ab (1000BASE-T)	IEEE802.3 (10BASE-T), IEEE802.3u (100BASE-TX)
Port Speed/Type/Port Number	10/100/1000Mbps/Half Duplex, Full Duplex/1	10/100Mbps/Half Duplex, Full Duplex/1
Wireless LAN		
Wireless Standard	IEEE802.11ax, IEEE802.11ac, IEEE802.11n, IEEE802.11a, IEEE802.11b, IEEE802.11g	IEEE802.11n, IEEE802.11a, IEEE802.11b, IEEE802.11g
IEEE802.11ax	-	-
Channel	5GHz : 25ch (36, 40, 44, 48ch [W52], 52, 56, 60, 64ch [W53], 100, 104, 108, 112, 116, 120, 124, 128, 132, 136, 140, 144ch [W56] 149, 153, 157, 161, 165ch [W58]) 6GHz : 24ch (1, 5, 9, 13, 17, 21, 25, 29, 33, 37, 41, 45, 49, 53, 57, 61, 65, 69, 73, 77, 81, 85, 89, 93ch)	-
Data transmission speed *1	2402 - 0.9Mbps [MCS0 -11, 0.8us/1.6us/3.2us GI]	-
IEEE802.11ac	-	-
Channel	5GHz : 25ch (36, 40, 44, 48ch [W52], 52, 56, 60, 64ch [W53], 100, 104, 108, 112, 116, 120, 124, 128, 132, 136, 140, 144ch [W56] 149, 153, 157, 161, 165ch [W58])	-
Data transmission speed *1	866 - 7.2Mbps [MCS0 - 9, Short/Long GI]	-
IEEE802.11n	-	-
Channel	Access point / Repeater Station 5GHz : 25ch (36, 40, 44, 48ch [W52], 52, 56, 60, 64ch [W53], 100, 104, 108, 112, 116, 120, 124, 128, 132, 136, 140, 144ch [W56] 149, 153, 157, 161, 165ch [W58])	5GHz : 9ch (36, 40, 44, 48ch [W52] 149, 153, 157, 161, 165ch [W58]) 5GHz : 21ch (36, 40, 44, 48ch [W52], 52, 56, 60, 64ch [W53], 100, 104, 108, 112, 116, 132, 136, 140ch [W56] 149, 153, 157, 161, 165ch [W58])
IEEE802.11a	-	-
Channel	Access point / Repeater Station 5GHz : 25ch (36, 40, 44, 48ch [W52], 52, 56, 60, 64ch [W53], 100, 104, 108, 112, 116, 120, 124, 128, 132, 136, 140, 144ch [W56] 149, 153, 157, 161, 165ch [W58]) 6GHz : 24ch (1, 5, 9, 13, 17, 21, 25, 29, 33, 37, 41, 45, 49, 53, 57, 61, 65, 69, 73, 77, 81, 85, 89, 93ch)	5GHz : 9ch (36, 40, 44, 48ch [W52] 149, 153, 157, 161, 165ch [W58]) 5GHz : 21ch (36, 40, 44, 48ch [W52], 52, 56, 60, 64ch [W53], 100, 104, 108, 112, 116, 132, 136, 140ch [W56] 149, 153, 157, 161, 165ch [W58])
Security	IEEE802.11ax/ac/n : WPA(AES), WPA2(AES), WPA3, WPA3 192bit, WPA-PSK(AES), WPA2-PSK(AES), WPA3-SAE, WSL(combination mentioned above are possible) IEEE802.11a/b/g : WEP(Open/ Shared Key /Auto), WPA(AES, TKIP), WPA-PSK(AES,TKIP), WPA2(AES, TKIP), WPA2-PSK(AES,TKIP), WPA3, WPA3 192bit, WPA3-SAE, IEEE802.1X(EAP-TLS, PEAP), WSL(combination mentioned above are possible)	IEEE802.11n : WPA(AES), WPA2(AES), WPA-PSK(AES), WPA2-PSK(AES), WSL(combination mentioned above are possible) IEEE802.11a/b/g : WEP(Open/ Shared Key /Auto), WPA(AES, TKIP), WPA-PSK(AES,TKIP), WPA2(AES, TKIP), WPA2-PSK(AES,TKIP), IEEE802.1X(EAP-TLS, PEAP), WSL(combination mentioned above are possible)
Input voltage range	5VDC±5% (DC Jack), 5 - 30VDC±5% (Power Connector)	
Rating input current	1.87A (5V DC input), 0.78A (12V DC input), 0.39A (24V DC input), 0.32A (30V DC input)	0.83A (5VDC input), 0.15A (30VDC input), 0.18A (PoE input 24V)
Operating ambient temperature	-20 - +40°C / 10 - 90%RH (without wind) -20 - +50°C / 10 - 90%RH (with air flow 0.6m/s)	0 - 50°C / 10 - 90%RH

- Wireless LAN devices may not operate normally due to factors such as the installation environment, the settings of the unit, and the communication load of the network system. Confirm that there are no problems by performing a verification in advance in an environment suitable for your use. When installing or installing wireless LAN devices, ask a specialist such as a system integrator who is familiar with the construction of wireless LAN network systems.
- When replacing this product (FLEXLAN 5000 series) with another series of wireless LAN devices (FLEXLAN 4000/3000/2000/1000/DS540 series, etc.), it may be necessary to rebuild the network system due to differences in product specifications and functions. When using this product, we recommend that you thoroughly evaluate the product in the environment in which it will be used by using a our company lending machine.

