

Digital I/O Board for Low Profile PCI
PIO-16/16T(LPCI)H



* Specifications, color and design of the products are subject to change without notice.

Features

Non-isolated TTL level input, non-isolated open-collector output
The product has the 16ch of non-isolated TTL level input and 16ch of non-isolated open-collector output whose response speed is 200nsec. The output rating is max. 30VDC, 40mA per ch.

All input signals can be used as interrupt request signals
You can use all input signals as interrupt request signals and also disable or enable the interrupt in bit units and select the edge of the input signals, at which to generate an interrupt.

Windows/Linux support device driver
Using the device driver API-TOOL makes it possible to create applications of Windows/Linux. In addition, a diagnostic program by which the operations of hardware can be checked is provided.

Equipped with digital filter to prevent wrong recognition of input signals from carrying noise or a chattering
This product has a digital filter to prevent wrong recognition of input signals from carrying noise or a chattering. All input terminals can be added a digital filter, and the setting can be performed by software.

Support for both of Low Profile and standard size slots
Support for both of Low Profile and standard size slots (interchangeable with a bundled bracket).

This product is a Low Profile size PCI bus-compliant interface board for input/output of digital signals. The product features 16 non-isolated TTL level inputs and 16 non-isolated open-collector outputs. You can use all of input signals as interrupt inputs. In addition, the digital filter function to prevent wrong recognition of input signals is provided. This product supports a Low Profile size slot and, if replaced with the supplied bracket, supports a standard size slot, too. Windows/Linux device driver is supported with this product.

- * The contents in this document are subject to change without notice.
- * Visit the CONTEC website to check the latest details in the document.
- * The information in the data sheets is as of June, 2026.

Specifications

Function specification

Item		Specifications
Input	Type	TTL-Level Input (Negative logic *1)
	Number of Channels	16ch (All available for interrupts) (1 common)
	Pull up resistance	10kΩ (1TTL load)
	Interrupt	Combine 16 interrupt signals to one interrupt request signal as the INTA. Either rising edge or falling edge of input signal can generate interrupt.
	Response time	200nsec within
Output	Type	Open Collector Output (Negative logic *1)
	Number of Channels	16ch (1 common)
	Output rated voltage	30VDC (Max.)
	Output rated current	40mA (perchannel) (Max.)
	Response time	200nsec within (Variable with pull-up resistance)
Common	Connecting distance	1.5m(Typ.) (depending on wiring environment)
	I/O address	Any 32-byte boundary
	Interruption level	1 level use
	Boards in one system	Maximum of 16 boards can be install in a same system.
	Power consumption	5VDC 100mA (Max)
	PCI bus specification	32bit, 33MHz, Universal key shapes supported *2
	Dimension (mm)	121.69(L) x 63.41(H)
	Weight	60g

*1 Data "0" and "1" correspond to the High and Low levels, respectively.
*2 This product requires power supply at +5V from an expansion slot (it does not work on a machine with a +3.3-V power supply alone).

Installation Environment Requirements

Item	Specifications
Operating ambient temperature	0 - 50°C
Operating ambient humidity	10 - 90%RH (No condensation)
Floating dust particles	Not to be excessive
Corrosive gases	None
Standard	VCCI Class A, CE Marking (EMC Directive Class A, RoHS Directive), UKCA

Support Software

Name	Contents	How to get
Windows Version Digital I/O Driver software API-DIO(WDM)	The Windows device driver is provided as a form of Windows API functions. Various sample programs such as C# and Visual Basic, .NET, Visual C++, Python etc. and diagnostic program useful for checking operation is provided.	Download from the CONTEC website *1
Linux Version Digital I/O Driver software API-DIO(LNX)	The Linux device driver is provided as a shared library. The software includes various sample programs such as gcc (C, C++) and Python programs as well as a configuration tool to configure the device settings.	Download from the CONTEC website *1
Software Development Tool Kits (SDK) and Support Software	In addition to the device drivers, we offer many software programs for using CONTEC devices in an easier manner.	Download from the CONTEC website *2

*1 Download the files from the following URL.

<https://www.contec.com/download/>

*2 For supported software, search the CONTEC website for this product and view the product page.

<https://www.contec.com/>

Optional Products

Product Name	Model type	Description
Shield Cable with Two 50-pin Mini-Ribbon Connector	PCB50PS-0.5P	0.5m
	PCB50PS-1.5P	1.5m
Shield Cable with One 50-pin Mini-Ribbon Connector	PCA50PS-0.5P	0.5m
	PCA50PS-1.5P	1.5m
Connection Conversion 0.5m Shield Cable (50p Ribbon to 37p D-SUB)	PCE50/37PS-0.5P	0.5m
Screw Terminal (M3 * 50P)	EPD-50A	*1 *3
Screw Terminal (M3 * 37P)	EPD-37A	*2 *3
Screw Terminal (M3.5 * 37)	EPD-37	*2
General Purpose Terminal	DTP-3C	*2
Screw Terminal	DTP-4C	*2
Signal monitor Accessory for Digital I/O (32bits)	CM-32L	*2

*1 PCB50PS-*P optional cable is required separately.

*2 PCE50/37PS-0.5P and PCB37P or PCB37PS optional cable is required separately.

*3 "Spring-up" type terminal is used to prevent terminal screws from falling off

Visit the CONTEC website for the latest optional products

Included Items

Product [PIO-16/16T(LPCI)H] ...1
 Standard Size Bracket...1
 Please read the following ... 1

Physical Dimensions

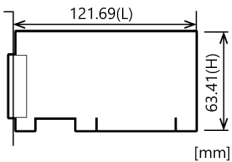

The standard outside dimension (L) is the distance from the end of the board to the outer surface of the slot cover.

Component Name

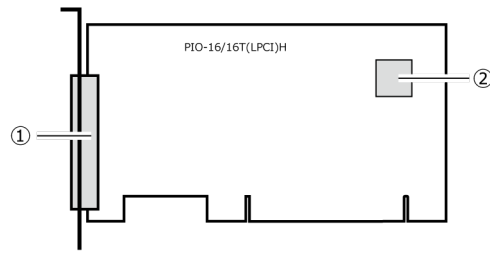

No.	Name
1	Interface Connector
2	Board ID Setting Switch

Connecting an Interface Connector

To connect an external device to this product, plug the cable from the device into the interface connector (CN1) shown below.

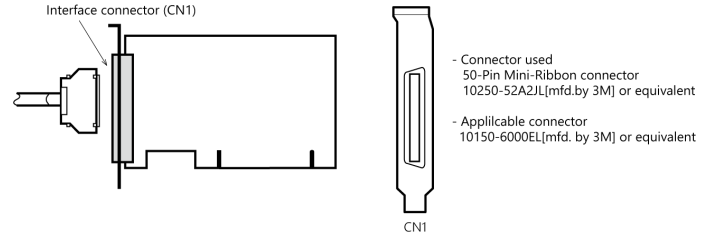

Layout on the Interface Connector(CN1)

Signal Common	GND	50		25	GND	Signal Common
Signal Common	GND	49		24	GND	Signal Common
+2 port (output)	O-20	48		23	O-30	+3 port (output)
	O-21	47		22	O-31	
	O-22	46		21	O-32	
	O-23	45		20	O-33	
	O-24	44		19	O-34	
	O-25	43		18	O-35	
	O-26	42		17	O-36	
	O-27	41		16	O-37	
+5V	Vcc	40		15	Vcc	+5V
+5V	Vcc	39		14	Vcc	+5V
	N.C.	38		13	N.C.	
Signal Common	GND	37		12	GND	Signal Common
Signal Common	GND	36		11	GND	Signal Common
+0 port (input)	I-00	35		10	I-10	+1 port (input)
	I-01	34	9	I-11		
	I-02	33	8	I-12		
	I-03	32	7	I-13		
	I-04	31	6	I-14		
	I-05	30	5	I-15		
	I-06	29	4	I-16		
I-07	28	3	I-17			
+5V	Vcc	27	2	Vcc	+5V	
+5V	Vcc	26	1	Vcc	+5V	

* I-00 - I-17 can be used as interrupt signal

Signal name	Description
I-00 - I-17	16 input signal pins. Connect output signals from the external device to these pins.
O-20 - O-37	16 output signal pins. Connect these pins to the input signal pins of the external device.
Vcc	These pins output power at +5 V.
GND	These pins are connected to the slot's GND.
N.C.	These pins are left unconnected.

CAUTION

To perform input/output using this product with the CONTEC device driver, specify logical ports and logical bits when calling each function. For details, refer to the "Relationships between API-TOOL Logical Ports/Bits and Connector Signal Pins" of Reference Manual.

Connecting Input and Output Signal

Input Circuit

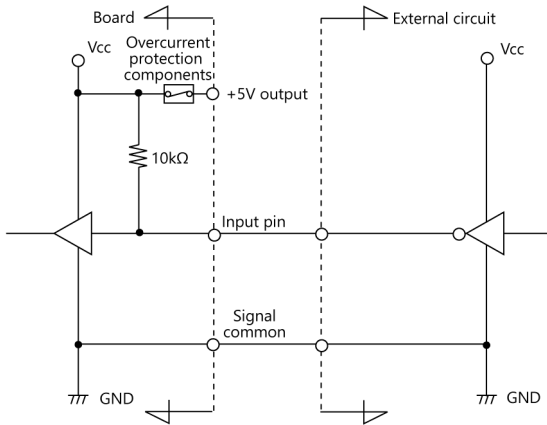

* I-xx represent an input pin.

One overcurrent protection components is connected for Vcc(+5V) terminal.

External digital signals given to signal inputs are TTL levels.

The individual input signals are passed to the personal computer as active low signals.

As each of the signal inputs is pulled up internally, the output of a relay contact or semiconductor switch can be connected directly between the signal input and the signal common pin.

Connecting a Switch (An Example to use Input I-00)

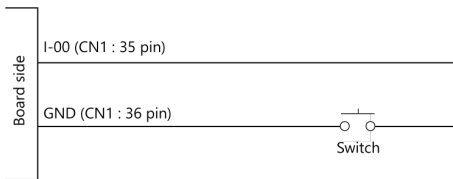

When the switch is ON, the corresponding bit contains 1.
When the switch is OFF, by contrast, the bit contains 0.

Output Circuit

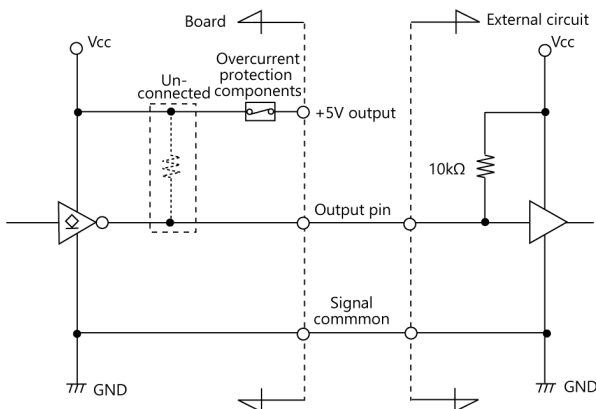

* O-xx represent an output pin.

One overcurrent protection components is connected for Vcc(+5V) terminal.

Signal outputs are open-collector outputs; individual output signals are sent to the external device as active low signals.

Note that each signal output must be pulled up at the external device as it is not pulled up internally.

CAUTION

When the PC is turned on, all outputs are reset to OFF.

Connection to the LED (An Example to use Output O-20)

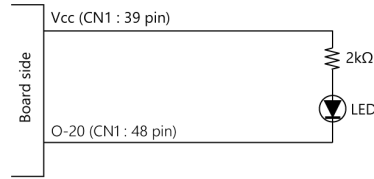

When "1" is output to a relevant bit, the corresponding LED comes on.
When "0" is output to the bit, in contrast, the LED goes out.

Block Diagram

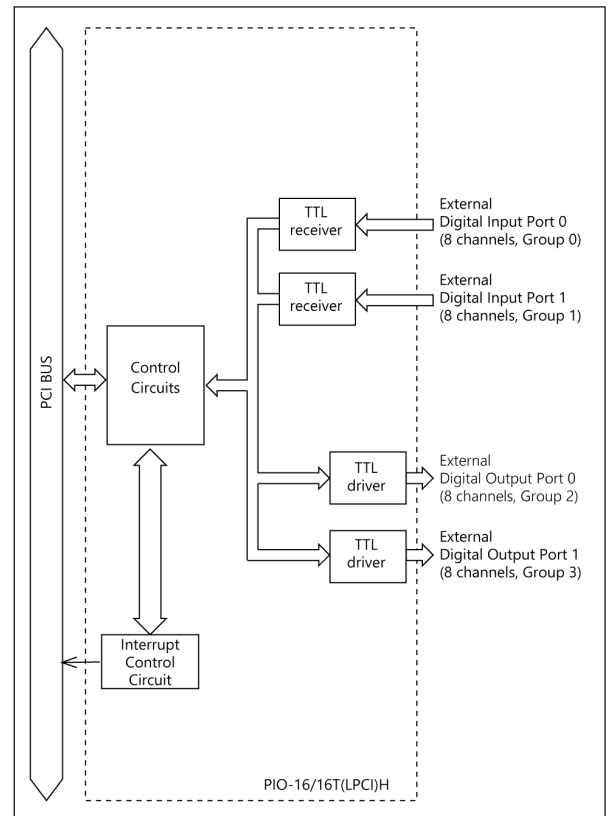

Differences from Conventional Products

Differences between the PIO-16/16T(LPCI)H and PIO-16/16T(PCI)

PIO-16/16T(LPCI)H has the following differences from the conventional PIO-16/16T(PCI).

- Different in connector shape and pin assignment
PIO-16/16T(LPCI)H : 50-Pin Mini-Ribbon connector
PIO-16/16T(LPCI) : 37-pin D-SUB
- The external dimensions of the board differ.
PIO-16/16T(LPCI)H : 121.69(L) x 63.41(H) mm
PIO-16/16T(LPCI) : 121.69(L) x 106.68(H) mm
- Different in the number of input signals available to interrupt requests
PIO-16/16T(LPCI)H : All of 16 channels
PIO-16/16T(LPCI) : 4 channels
- Different in the expression to calculate the digital filter time (n: setting value)
PIO-16/16T(LPCI)H : $2^n / (8 \times 10^6)$
PIO-16/16T(LPCI) : $2^n / (16 \times 10^6)$
- Different in interrupt level resource allocation
PIO-16/16T(LPCI)H : Automatically allocates on interrupt level.
PIO-16/16T(LPCI) : Uses a jumper switch to select whether to allocate interrupt levels.