

Digital I/O Board for PCI
PIO-16/16T(PCI)H



* Specifications, color and design of the products are subject to change without notice.

Features

Non-isolated TTL level input, non-isolated open-collector output
This product has the 16ch of non-isolated TTL level input and 16ch of non-isolated open-collector output whose response time is 200nsec. The output rating is max. 30VDC, 40mA per ch.

All input signals can be used as interrupt request signals
You can use all input signals as interrupt request signals and also disable or enable the interrupt in bit units and select the edge of the input signals, at which to generate an interrupt.

Equipped with digital filter to prevent wrong recognition of input signals from carrying noise or a chattering
This product has a digital filter to prevent wrong recognition of input signals from carrying noise or a chattering. All input terminals can be added a digital filter, and the setting can be performed by software.

Windows/Linux support device driver
Using the device driver API-TOOL makes it possible to create applications of Windows/Linux. In addition, a diagnostic program by which the operations of hardware can be checked is provided.

Functions and connectors are compatible with PCI compatible board PIO-16/16T(PCI)H
PIO-16/16T(PCI)H : The functions same with PCI compatible board PIO-16/16T(PCI) are provided.

In addition, as there is compatibility in terms of connector shape and pin assignments, it is easy to migrate from the existing system.

Packing List

Product...1
Please read the following...1

Physical Dimensions

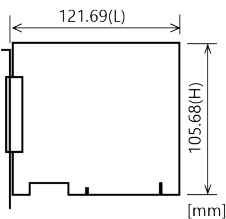

The standard outside dimension (L) is the distance from the end of the board to the outer surface of the slot cover.

This product is a PCI bus-compliant interface board for input/output of digital signals.

This product features 16 non-isolated TTL level inputs and 16 non-isolated open-collector outputs. You can use all of input signals as interrupt inputs. In addition, the digital filter function to prevent wrong recognition of input signals is provided. Windows/Linux device driver is supported with this product.

- * The contents in this document are subject to change without notice.
- * Visit the CONTEC website to check the latest details in the document.
- * The information in the data sheets is as of May, 2026.

Specifications

Function specification

Item		Specifications
Input	Type	Non-isolated TTL-Level Input (Negative logic *1)
	Number of Channels	16 channels (all available for interrupts)
	Input resistance	10kΩ
	Interrupts	Combine 16 interrupt signals to one interrupt request signal as the INTA. Either rising edge or falling edge of input signal can generate interrupt.
	Response time	200nsec within
Output	Type	Open Collector Output (Negative logic *1)
	Number of Channels	16ch (1common)
	Output rated voltage	30VDC (Max)
	Output rated current	40mA/channel (Max)
	Response time	200nsec within
Common	Connecting distance	1.5m(Typ.)(depending on wiring environment)
	I/O address	Any 32-byte boundary
	Interruption level	1 level use
	Boards in one system	Maximum of 16 boards can be install in a same system.
	Power consumption	5DC 200mA (Max)
	Bus specification	32bit, 33MHz, Universal key shapes supported *2
	Dimension (mm)	121.69(L)×105.68(H)
	Weight	100g

*1 Data "0" and "1" correspond to the High and Low levels, respectively.

*2 This board requires power supply at +5V from an expansion slot (it does not work on a machine with a +3.3V power supply alone).

Installation Environment Requirements

Item	Specifications
Operating ambient temperature	0 - 50°C
Operating ambient humidity	10 - 90%RH (No condensation)
Floating dust particles	Not to be excessive
Corrosive gases	None
Standard	VCCI Class A, CE Marking (EMC Directive Class A, RoHS Directive), UKCA

Support Software

Name	Contents	How to get
Windows Version Digital I/O Driver software API-DIO(WDM)	The Windows device driver is provided as a form of Windows API functions. Various sample programs such as C# and Visual Basic, .NET, Visual C++, Python etc. and diagnostic program useful for checking operation is provided.	Download from the CONTEC website *1
Linux Version Digital I/O Driver software API-DIO(LNX)	The Linux device driver is provided as a shared library. The software includes various sample programs such as gcc (C, C++) and Python programs, as well as a configuration tool to configure the device settings.	Download from the CONTEC website *1
Software Development Tool Kits (SDK) and Support Software	In addition to the device drivers, we offer many software programs for using CONTEC devices in an easier manner.	Download from the CONTEC website *2

*1 Download the files from the following URL.

<https://www.contec.com/download/>

*2 For supported software, search the CONTEC website for this product and view the product page.

<https://www.contec.com/>

Optional Products

Product Name	Model type	Description
Shield Cable with two 37-pin D-type connectors	PCB37PS-0.5P	0.5m
	PCB37PS-1.5P	1.5m
Flat Cable with 37-Pin D-type Connectors on 2Ends	PCB37P-1.5	1.5m
Shield Cable with One 37pin D-type Connector	PCA37PS-0.5P	0.5m
	PCA37PS-1.5P	1.5m
Flat Cable with a 37Pin D-type Connectors	PCA37P-1.5	1.5m
Screw Terminal (M3 * 37P)	EPD-37A	*1 *2
Screw Terminal (M3.5 * 37)	EPD-37	*2
General Purpose Terminal	DTP-3C	*2
Screw Terminal	DTP-4C	*2
Signal monitor Accessory for Digital I/O (32bits)	CM-32L	*2

*1 "Spring-up" type terminal is used to prevent terminal screws from falling off.

*2 PCB37P or PCB37PS optional cable is required separately.

Connecting an Interface Connector

Connecting an Interface Connector

To connect an external device to this product, plug the cable from the device into the interface connector (CN1) shown below.

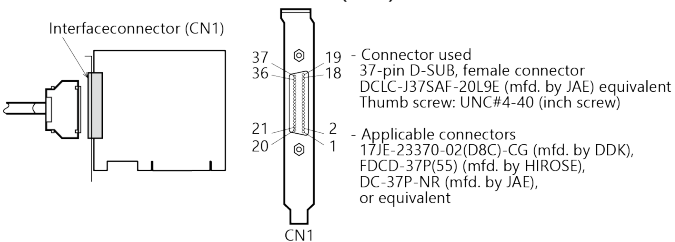

Layout on the Interface Connector(CN1)

Signal name	Pin	Signal name	Pin	
+5V	Vcc 37	19	N.C.	
+3 port (Output)	O-37	36	18	Vcc
	O-36	35	17	I-17
	O-35	34	16	I-16
	O-34	33	15	I-15
	O-33	32	14	I-14
	O-32	31	13	I-13
	O-31	30	12	I-12
	O-30	29	11	I-11
+2 port (Output)	O-27	28	10	I-10
	O-26	27	9	I-07
	O-25	26	8	I-06
	O-24	25	7	I-05
	O-23	24	6	I-04
	O-22	23	5	I-03
	O-21	22	4	I-02
	O-20	21	3	I-01
Signal Common	GND 20	2	I-00	
		1	GND	
			Signal Common	

* I-00 - I-17 can be used as interrupt signal.

Signal name	Description
I-00 - I-17	16 input signal pins. Connect output signals from the external device to these pins.
O-20 - O-37	16 output signal pins. Connect these pins to the input signal pins of the external device.
Vcc	This pin outputs power at +5V.
GND	This pin is connected to the slot's GND.
N.C.	This pin is left unconnected.

Connecting Input and Output Signals

Input Circuit

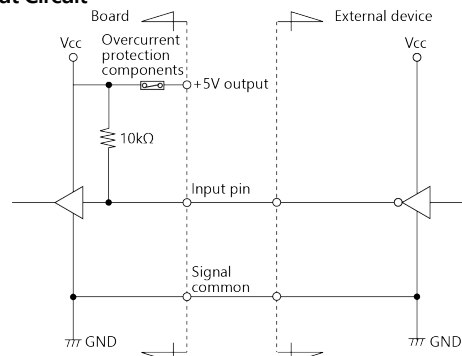

* I-xx represents an input pin.

One overcurrent protection components is connected for Vcc(+5V) terminal.

The input circuits of interface blocks of the PIO-16/16T(PCI)H are illustrated in the figure above. External digital signals given to signal inputs are TTL levels. The individual input signals are passed to the personal computer as negative logic signals. As each of the signal inputs is pulled up internally, the output of a relay contact or semiconductor switch can be connected directly between the signal input and the signal common pin.

Connecting a Switch (An Example to use Input I00)

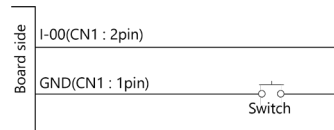

When the switch is ON, the corresponding bit contains 1.
When the switch is OFF, by contrast, the bit contains 0.

Output Circuit

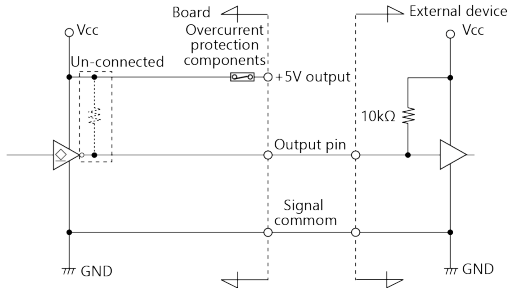

*O-xx represent an output pin.
One overcurrent protection components is connected for Vcc(+5V) terminal.

The output circuits of interface blocks of the PIO-16/16T(PCI)H are illustrated in the figure above. Signal outputs are open-collector outputs; individual output signals are sent to the external device as negative logic signals. Note that each signal output must be pulled up at the external device as it is not pulled up internally.

CAUTION

When the PC is turned on, all output are reset to OFF.

Connection to the LED (An Example to use Output O-20)

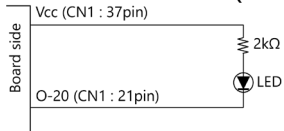

When "1" is output to a relevant bit, the corresponding LED comes on.
When "0" is output to the bit, in contrast, the LED goes out.

Surge Protection

A protection function, which prevents excessive current flow from the +5V outputs, is attached to this board. In case of accidental short of the +5V output and GND, for example, the function works.

-Examples of use of relay coil

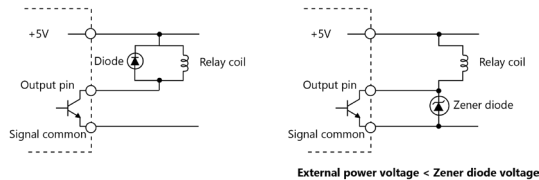

-Examples of use of lump

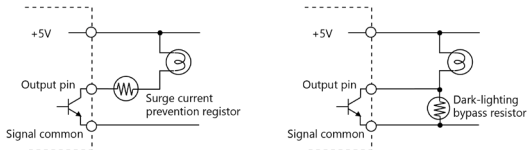

CAUTION

The protection circuit must be installed less than 50 cm from the load and contact to provide effective protection.

A Protection Function of the +5V Outputs

A protection function, which prevents excessive current flow from the +5V outputs, is attached to this board. In case of accidental short of the +5V output and GND, for example, the function works.

Block Diagram

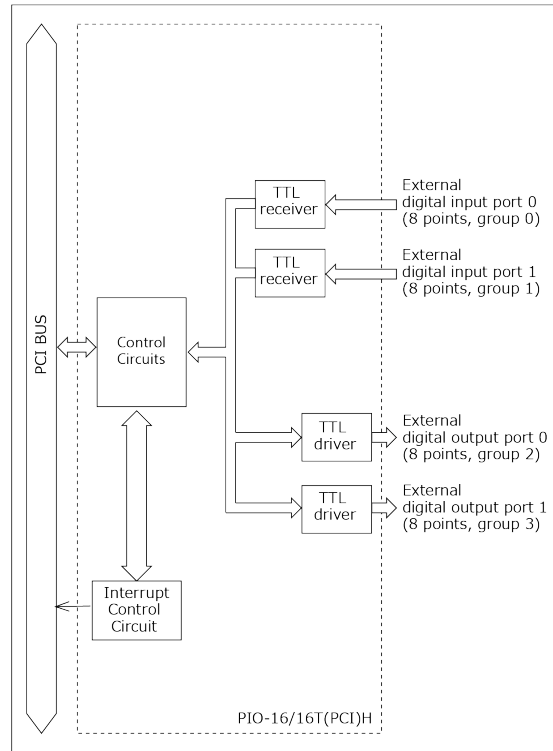

Nomenclature of Product Components

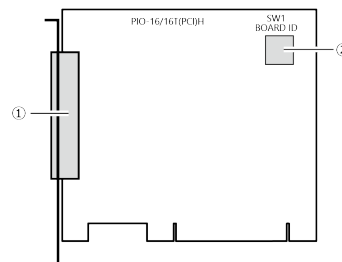

No.	Name
1	Interface Connector
2	Board ID Setting Switch