

Digital Output Board with Opto-Isolation for PCI
PO-32L(PCI)H



* Specifications, color and design of the products are subject to change without notice.

Features

Opto-coupler isolated open-collector output (current sink type)
 PIO-16/16L(PCI)H has the 16ch of opto-coupler isolated input (supporting current sink output) and 16ch of opto-coupler isolated open-collector output (current sink type) whose response time is 200μsec. Common terminal provided per 16channels, capable of supporting a different external power supply. Supporting driver voltages of 12 - 24 VDC for I/O.

Opto-coupler bus isolation

As the PCI bus (PC) is isolated from the input and output interfaces by opto-couplers, this product has excellent noise performance.

Windows/Linux support device driver

Using the device driver API-TOOL makes it possible to create applications of Windows/Linux. In addition, a diagnostic program by which the operations of hardware can be checked is provided.

Zener diode for surge voltage protection and the circuit for overcurrent protection.

Zener diodes are connected to the output circuits to protect against surge voltages. In addition, the output circuit, it attaches the overcurrent protection circuit at the output 8-channel unit. The output rating is max. 35VDC, 100mA per channel.

This product is a PCI bus-compliant interface board for output of digital signals. This product can output digital signals at 12 - 24VDC.

PO-32L(PCI)H features 32 opto-coupler isolated open-collector outputs (current sinking type). In addition, output transistor protection circuit (surge voltage protection and overcurrent protection).

Windows/Linux device driver is supported with this product.

- * The contents in this document are subject to change without notice.
- * Visit the CONTEC website to check the latest details in the document.
- * The information in the data sheets is as of January, 2026.

Specifications

Function specification

Item		Specifications
Output	Type	Opto-Isolated Open Collector Output (current sinking type) (Negative logic *1)
	Number of Channels	32ch (One common power supply per 16 channels)
	Output rated voltage	35VDC (Max)
	Output rated current	100mA/channel (Max)
	Residual voltage with output on	0.5V or less (Output current ≤ 50mA), 1.0V or less (Output current ≤ 100mA)
	Surge protector	Zener diode RD47FM(Renesas) or equivalent
	Response time	200μsec within
Common	Connecting distance	50m(Typ.)(depending on wiring environment)
	I/O address	Any 32-byte boundary
	Interruption level	Not used
	Boards in one system	Maximum of 16 boards can be install in a same system.
	Isolated voltage	1000Vrms
	External circuit power supply	12 - 24VDC(±10%)
	Power consumption	5VDC 200mA (Max)
	PCI bus specification	32bit, 33MHz, Universal key shapes supported *2
	Dimension (mm)	121.69(L) x 105.68(H)
	Weight	130g

*1 Data "0" and "1" correspond to the High and Low levels, respectively.

*2 This product requires power supply at +5 V from an expansion slot (it does not work on a machine with a +3.3-V power supply alone).

Installation Environment Requirements

Item	Specifications
Operating ambient temperature	0 - +50°C
Operating ambient humidity	10 - 90%RH (No condensation)
Floating dust particles	Not to be excessive
Corrosive gases	None
Standard	VCCI Class A, CE Marking (EMC Directive Class A, RoHS Directive), UKCA

Support Software

Name	Contents	How to get
Windows Version Digital I/O Driver software API-DIO(WDM)	The Windows device driver is provided as a form of Windows API functions. Various sample programs such as C# and Visual Basic .NET, Visual C++, Python etc. and diagnostic program useful for checking operation is provided.	Download from the CONTEC website *1
Linux Version Digital I/O Driver software API-DIO(LNX)	The Linux device driver is provided as a shared library. The software includes various sample programs such as gcc (C, C++) and Python programs, as well as a configuration tool to configure the device settings.	Download from the CONTEC website *1
Software Development Tool Kits (SDK) and Support Software	In addition to the device drivers, we offer many software programs for using CONTEC devices in an easier manner.	Download from the CONTEC website *2

*1 Download the files from the following URL

<https://www.contec.com/download/>

*2 For supported software, search the CONTEC website for this product and view the product page.

<https://www.contec.com/>

Optional Products

Product Name	Model type	Description
Shield Cable with 37-pin D-Type Connector at Both Ends (Mold Type)	PCB37PS-0.5P	0.5m
	PCB37PS-1.5P	1.5m
	PCB37PS-3P	3m
	PCB37PS-5P	5m
Flat Cable with 37-Pin D-Type Connector at Both Ends	PCB37P-1.5	1.5m
	PCB37P-3	3m
	PCB37P-5	5m
Shield Cable with 37-pin D-Type Connector at One End (Mold Type)	PCA37PS-0.5P	0.5m
	PCA37PS-1.5P	1.5m
	PCA37PS-3P	3m
	PCA37PS-5P	5m
Flat Cable with 37-pin D-Type Connector at One End	PCA37P-1.5	1.5m
	PCA37P-3	3m
	PCA37P-5	5m
Screw Terminal Unit (M3 x 37P)	EPD-37A	*1 *2
Screw Terminal Unit (M3.5 x 37P)	EPD-37	*1
Termination Panel (M3 x 37P)	DTP-3C	*1
Termination Panel (M2.5 x 37P)	DTP-4C	*1
Signal Monitor for Digital I/O (32bit)	CM-32L	*1

*1 PCB37P or PCB37PS optional cable is required separately.

*2 "Spring-up" type terminal is used to prevent terminal screws from falling off.

Visit the CONTEC website for the latest optional products.

Included Items

Product [PO-32L(PCI)H] ...1
Please read the following ... 1

External Dimensions

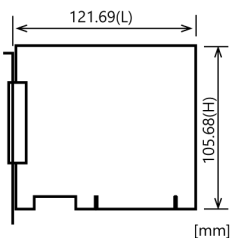

The standard outside dimension (L) is the distance from the end of the board to the outer surface of the slot cover.

Component Name

Built-in power setting function

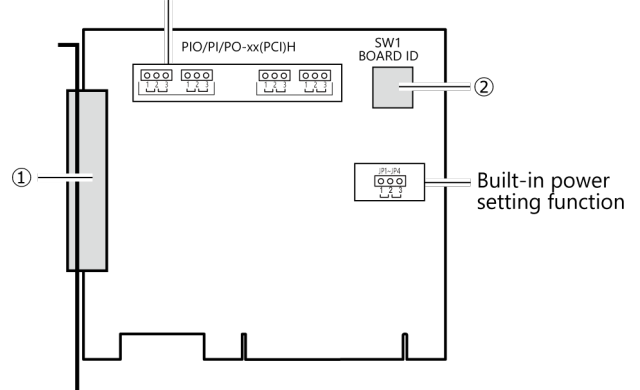

No.	Name
1	Interface Connector
2	Board ID Setting Switch

CAUTION

The product doesn't have the built-in power setting function.

Connecting an Interface Connector

To connect an external device to this product, plug the cable from the device into the interface connector (CN1) shown below.

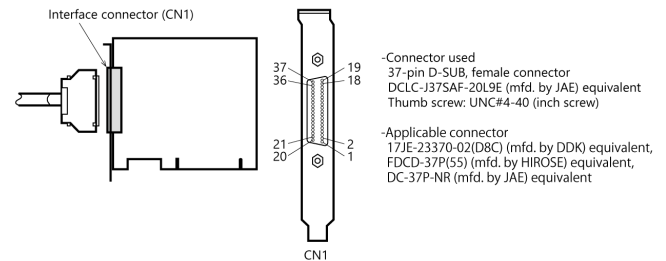

Layout on the Interface Connector(CN1)

Common minus pin for +0/+1 output ports	ON-0/1	1	20	ON-2/3	Common minus pin for +2/+3 output ports
+0 port (Output)	O-00	2	21	O-20	+2 port (Output)
	O-01	3	22	O-21	
	O-02	4	23	O-22	
	O-03	5	24	O-23	
	O-04	6	25	O-24	
	O-05	7	26	O-25	
	O-06	8	27	O-26	
	O-07	9	28	O-27	
	O-10	10	29	O-30	
	O-11	11	30	O-31	
	O-12	12	31	O-32	
	O-13	13	32	O-33	
	O-14	14	33	O-34	
	O-15	15	34	O-35	
	O-16	16	35	O-36	
	O-17	17	36	O-37	
	Common plus pin for +0/+1 output ports	OP-0/1	18	37	
N.C.		19			

Signal name	Description
O-00 - O-37	32 output signal pins. Connect these pins to the input signal pins of the external device.
OP-0/1	Connect the positive side of the external power supply. This pin is common to 16 output signal pins.
OP-2/3	Connect the positive side of the external power supply. This pin is common to 16 output signal pins.

Signal name	Description
ON-0/1	Connect the negative side of the external power supply. This pin is common to 16 output signal pins.
ON-2/3	Connect the negative side of the external power supply. This pin is common to 16 output signal pins.
N.C.	This pin is left unconnected.

CAUTION

To perform input/output using this product with the CONTEC device driver, specify logical ports and logical bits when calling each function. For details, refer to the "Relationships between API-TOOL Logical Ports/Bits and Connector Signal Pins" of Reference Manual.

Connecting Output Signal

Output Circuit

Connect the output signals to a current-driven controlled device such as a relay or LED.

The connection requires an external power supply to feed currents. The product controls turning on/off the current-driven controlled device using a digital value.

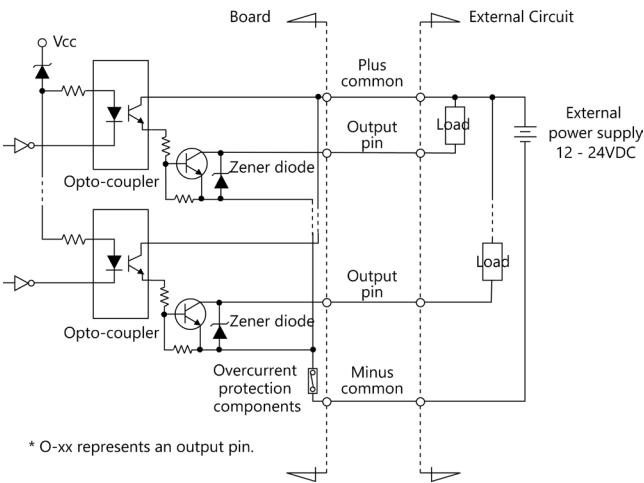

The output circuits of interface blocks of the product are illustrated in the figure above.

The signal output section is an opto-coupler isolated, open-collector output (current sink type).

This product therefore requires the on-board internal power supply or the external power supply to drive the output section of this product.

The rated output current per channel is 100mA at maximum.

The output section can also be connected to a TTL level input as it uses a low-saturated transistor for output.

The residual voltage (low-level voltage) between the collector and emitter with the output on is 0.5V or less at an output current within 50mA or at most 1.0V at an output current within 100mA.

A zener diode is connected to the output transistor for protection from surge voltages.

An overcurrent protection component is provided for every 8 output transistors.

CAUTION

When the PC is turned on, all outputs are reset to OFF.

Connection to the LED (An Example to use Output O-20)

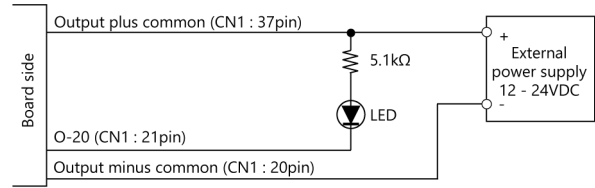

When "1" is output to a relevant bit, the corresponding LED comes on. When "0" is output to the bit, in contrast, the LED goes out.

Example of Connection to TTL Level Input (Connection Example of Output and TTL level Input Signal)

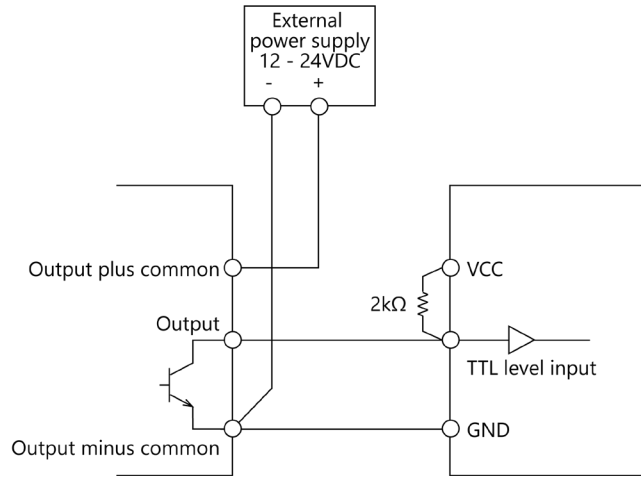

Connecting the Sink Type Output and Sink Output Support Input

The following example shows a connection between a sink type output (output board) and a sink output support input (input board). Refer to this connection example when you connect such boards to each other.

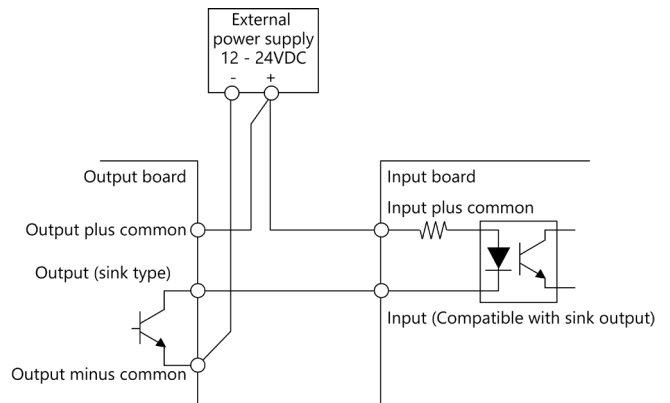

Block Diagram

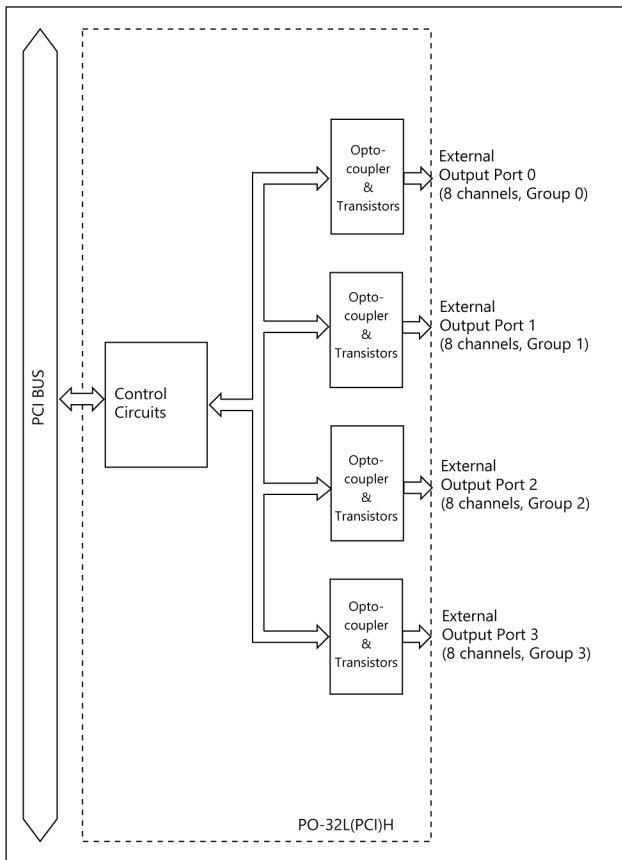

Differences from Conventional Products

Differences between the PO-32L(PCI)H and PO-32L(PCI)

The PO-32L(PCI)H is connector-pin compatible with the conventional PO-32L(PCI) but has the following differences from it:

- (1) Protective elements provided for outputs
 - PO-32L(PCI)H : Surge protector: Zener diode
 - PO-32L(PCI) : Nothing
- (2) The external dimensions of the board differ.
 - PO-32L(PCI)H : 121.69(L) x 105.68(H) mm
 - PO-32L(PCI) : 176.41(L) x 106.68(H) mm